

# **YC310LC-8 Hydraulic YC360LC-8 Excavator**

## **Operation Manual**

**This manual comes to you with the Hydraulic excavator.  
Please preserved carefully.**



Incorrect operation of the machine will cause death. Thus, before using this machine, you should do what described as following.

- Keep in mind the safety procedures of the machine and the correct use specifications.
- Read to understand the content related to the safe handling of the machine in the manual.
- Understand and be familiar with all of the safety signs on the machine.
- Keep unnecessary personnel to leave the workplace.
- Before the formal operation in the workplace, you should have prior training of the safe operation of the machine.

You are responsible for compliance with relevant laws and regulations and to comply with the relevant guidance of Yuchai Heavy Industry Co., Ltd. for operating and maintaining the machine.



# Contents

## 1.

To the Users .....	2
Product Information .....	3
Direction of the Machine .....	5
Composition of the Machine .....	7
Technical Specifications .....	8
General Safety .....	2
Safety Tips .....	3
Safety Equipment .....	4
Safety Signs .....	5
Workplace Safety .....	13
Safe Operation .....	14
Transport and Handling Machine .....	34
Stop the Machine and the Maintenance .....	35
Fire Prevention, Explosion-proof and Anti-poisoning .....	36
Battery .....	37
Hydraulic System .....	39
Overview of Operating Equipment .....	2
Monitor .....	3
Main Screen and Basic Operations .....	4
Left Dashboard .....	9
Command Control Panel (cab left) .....	11
Safety Locking Parts .....	12
Manipulation of the Working Device and the Rotary Equipment .....	13
Walking Manipulation .....	14
Throttle Operation .....	15
Driver's Seat .....	16
Seat Belt .....	17
Air-conditioning Control .....	18
Radio .....	22
Doors and Windows .....	24
Preparations before Operating this Machine .....	2
Engine Operation .....	3
Getting in or out of the Machine .....	7
Moving of the Machine .....	8
Turning the Machine .....	10
Rotation of the Machine .....	13
Selection of Machine Work Mode .....	14

Working Device Operation .....	15
Working on Slopes or in Water.....	17
Out of the Muddy Environment .....	18
Construction Operations Guide.....	19
Disassembly and Installation of the Bucket.....	21
Parking the Machine .....	22
After Operation.....	23
Handling and Transport of the Machine .....	24
Operating under the Hot or Cold Climate.....	29
Storage of the Machine .....	30
Reasons of Technical Failures and Solutions .....	32
Maintenance Knowledge.....	2
Maintenance Summary .....	4
Parts of Mandatory Replacement.....	6
Oil Selection Table .....	7
Tightening Torque.....	8
Regular Inspection and Maintenance Table .....	11
Regular Inspection and Maintenance Table (continued).....	13
Routine Examination .....	15
Engine Fuel System .....	16
Engine Cooling System.....	21
Engine Lubrication System .....	25
Engine Intake System .....	28
Other Maintenance of the Engine .....	29
Hydraulic System .....	30
Battery .....	38
Reducer.....	40
Track .....	43
Supporting wheel, under roller and idler .....	45
Lubricating.....	46
Air Conditioning.....	47
Bucket Teeth Replacement .....	50
Washing the Floor Pads .....	51
Safety issues.....	2
Accessories Installation and Removal Steps .....	4
Accessories Instruction Guide.....	5
Daily Inspection of Hydraulic Breaking Hammer.....	10

1

---

**Foreword**

## To the Users

Dear User:

Welcome you use Yuchai Heavy excavators and thank you for your strong cooperation with Yuchai business.

The manual is mainly provided for the use of the drivers and maintenance personnel. Hope you can read the manual carefully before the operation and maintenance of the machine, and be in strict accordance with the manual on safety procedures, use methods, lubrication and regular maintenance requirements. The proper methods, regular maintenance and repair are the necessary guarantees for the machine to work reliably and extend work life, as well as to play a good role in the work.

Please make the overhaul repair and adjust the machine in the repair stations and agencies that are commissioned by our company, and use the genuine accessories and spare parts provided by our company. If non-genuine accessories and parts have been used, then perhaps there is no significant impact on the machine, but they are likely to cause a series of adverse consequences to the machine in the future. If the machine failures are caused by the non-genuine accessories, parts or the organization without the authorization of our Company, even in the warranty period, Yuchai Heavy Industry Co., Ltd. does not assume the warranty service.

Based on the principle of "Customer First", Yuchai Heavy constantly improves products to provide the best products to the users. Thus, the improvement may be implemented at any time, without replacing the information and prior notice to the product on sale.

Sincerely hope that this machine can serve you better and create greater value under your proper use and care.

Guang Xi Yuchai Heavy Industry Co., Ltd.

## Product Information

When you need know the basic information of the machine, you can view the location in the picture.

- **Whole Machine Information (the whole machine nameplate is on the left front side of the platform)**

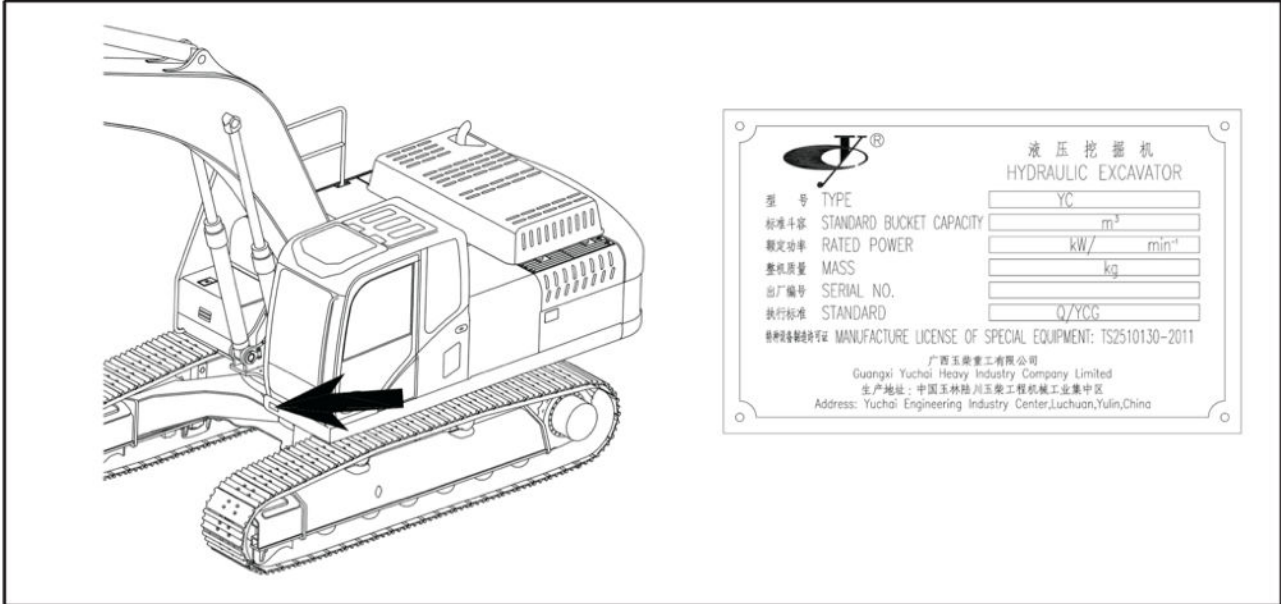

- **Engine Information**

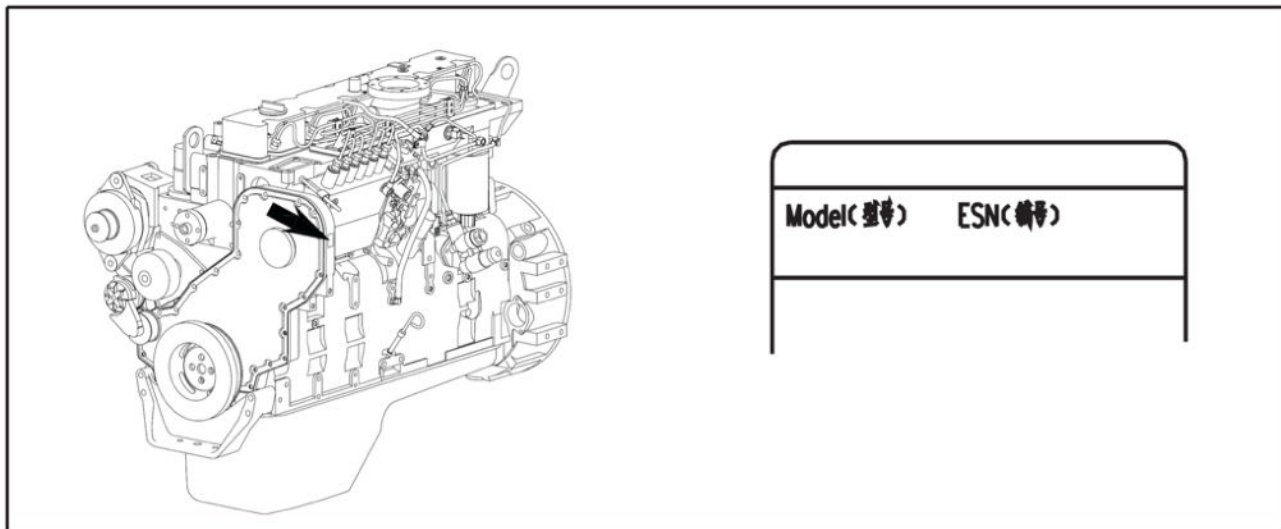

- **Machine Operating Information (the operating information of the machine can be displayed by the monitor in the cab)**

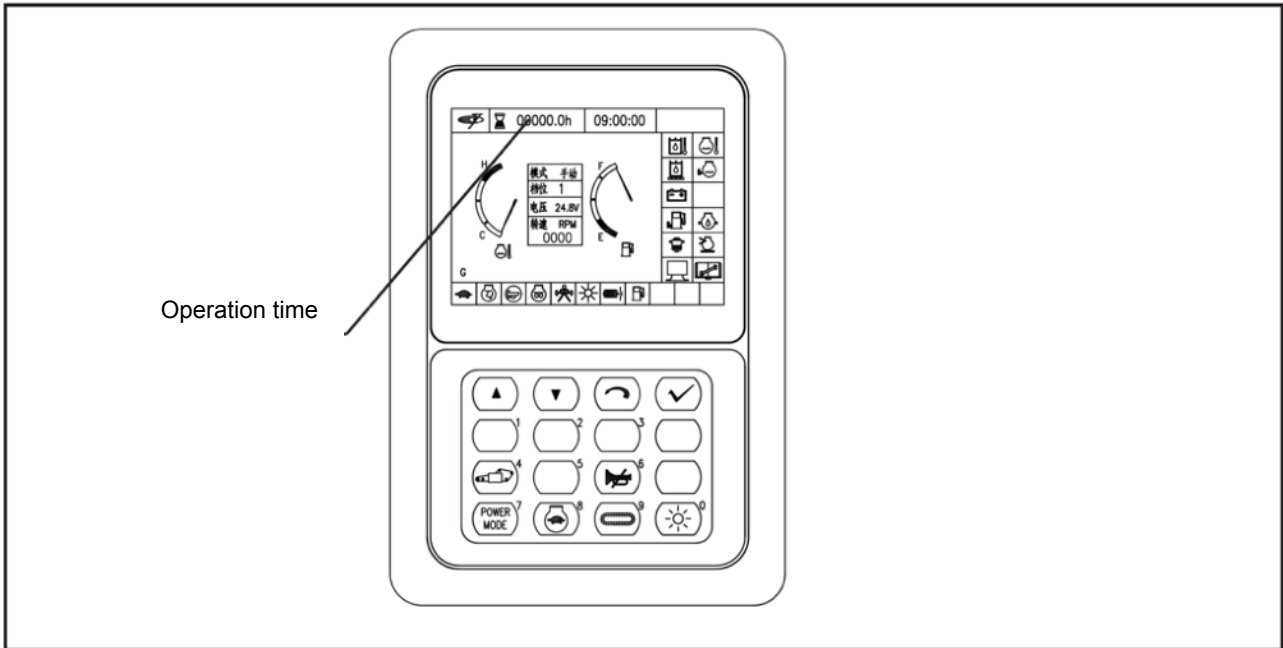

## Machine File

Please fill the table below with serial number of your machine and its engine and other data. When you need to buy machine parts or want to obtain the information, you can tell Yuchai these codes.

Please record these numbers, and keep them well with the product certification. In case that your machine is stolen, you can submit the information to the local public security organs.

	<ul style="list-style-type: none"> <li>● Machine Model _____</li> <li>● Machine serial number _____</li> <li>● Engine serial number _____</li> <li>● Information of the dealer _____            _____            _____            _____</li> </ul>
---	--



## Direction of the Machine

The directions of front, back, left, right, up and down in the manual refer to the directions as shown in the following diagram.

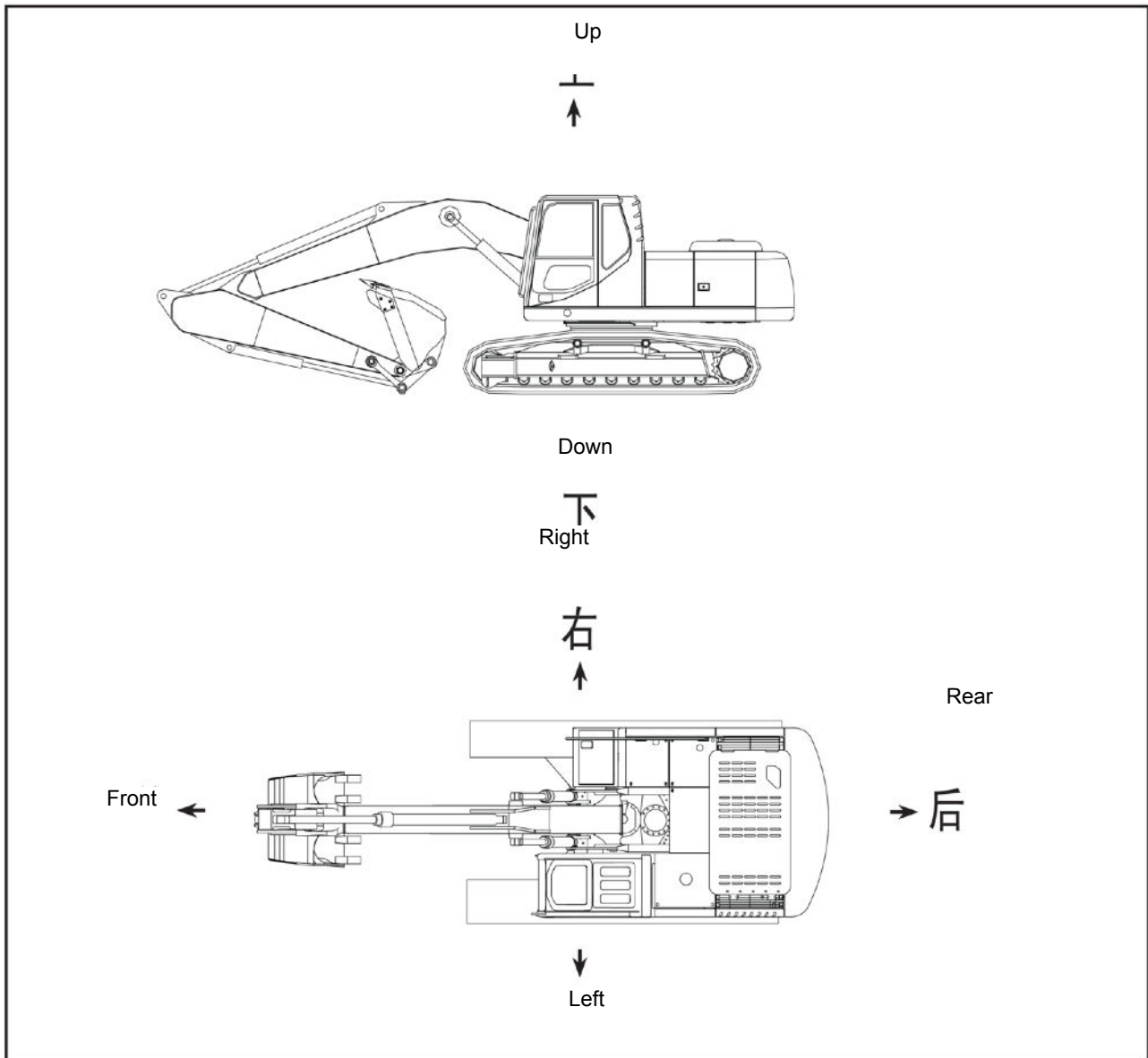



## Composition of the Machine

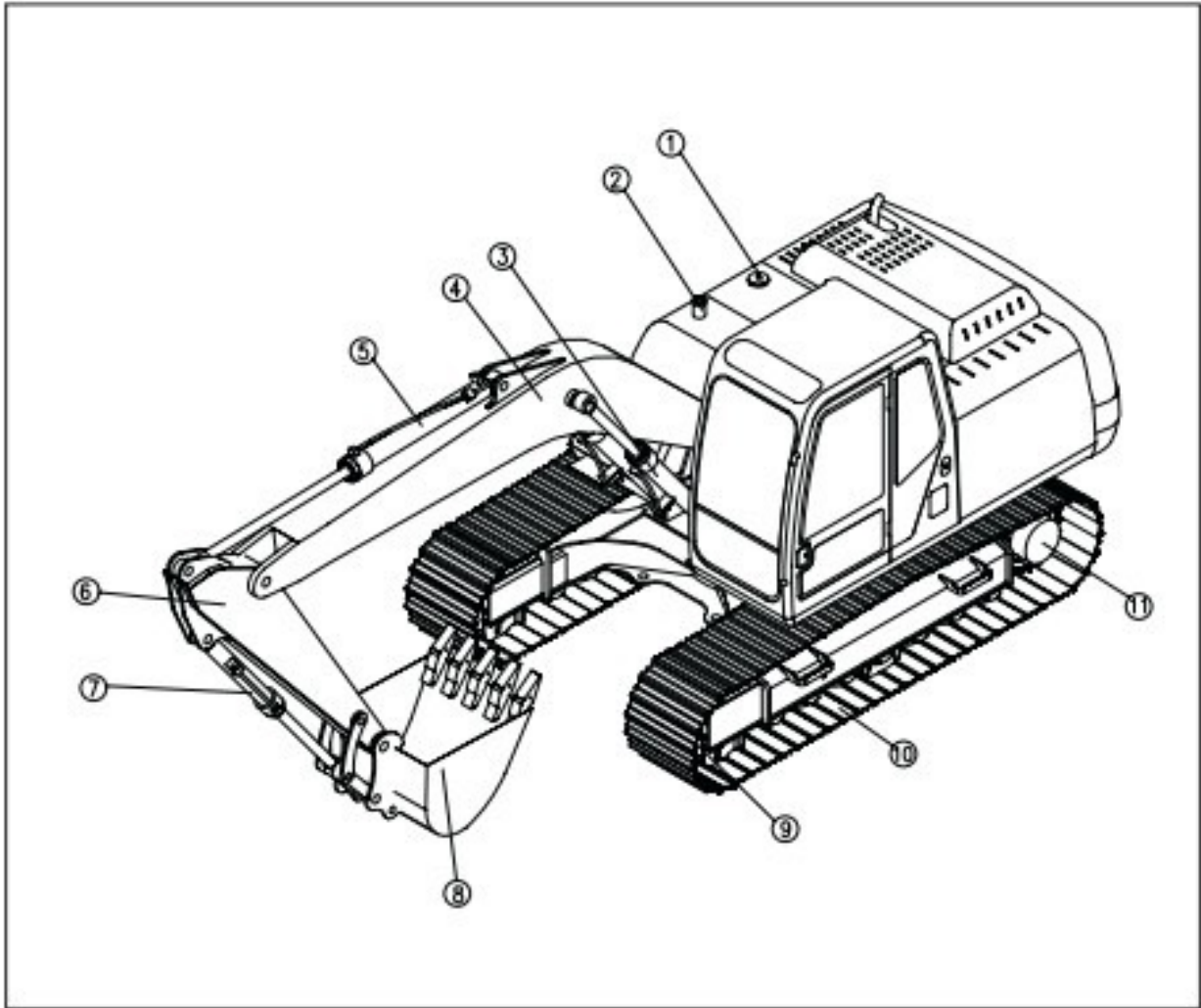

- |                       |                        |
|-----------------------|------------------------|
| 1. hydraulic oil tank | 7. Bucket oil cylinder |
| 2. fuel tank          | 8. Bucket              |
| 3. Boom Cylinder      | 9. Guide wheel         |
| 4. Boom               | 10. Track              |
| 5. Stick Cylinder     | 11. Driving wheel      |
| 6. Stick              |                        |

## Technical Specifications

<b>1. Structure size parameters</b>				
<b>Code</b>	<b>Item</b>	<b>Unit</b>	<b>YC310-8</b>	<b>YC360-8</b>
			<b>895</b>	<b>896</b>
	Operating Weight	Kg	31640	33620
	Standard bucket capacity	M <sup>3</sup>	1.43	1.63
	Engine Name		Cummins 6C8.3	Cummins 6C8.3
	Engine power	KW/rpm	186/2200	186/2200
<b>A</b>	Length	mm	10795	11250
<b>B</b>	Height	mm	3360	3160
<b>C</b>	Overall Width	mm	3260	3260
<b>D</b>	Track width	mm	600	600
<b>E</b>	Platform Rotation radius	mm	3364	3552
<b>F</b>	Track length	mm	4961	4961
<b>G</b>	Tread	mm	2060	2060
<b>H</b>	Chassis passing height	mm	530	530
<b>J</b>	External platform width	mm	2980	2980
<b>L</b>	Platform ground clearance	mm	1245.5	1245.5
	Maximum driving speed	Km/h	5.3	5.2
	Platform slewing speed	Rpm	10.7	9.5

Note: The above structural parameters are the nominal value, and their changes in the plant are without prior notice.

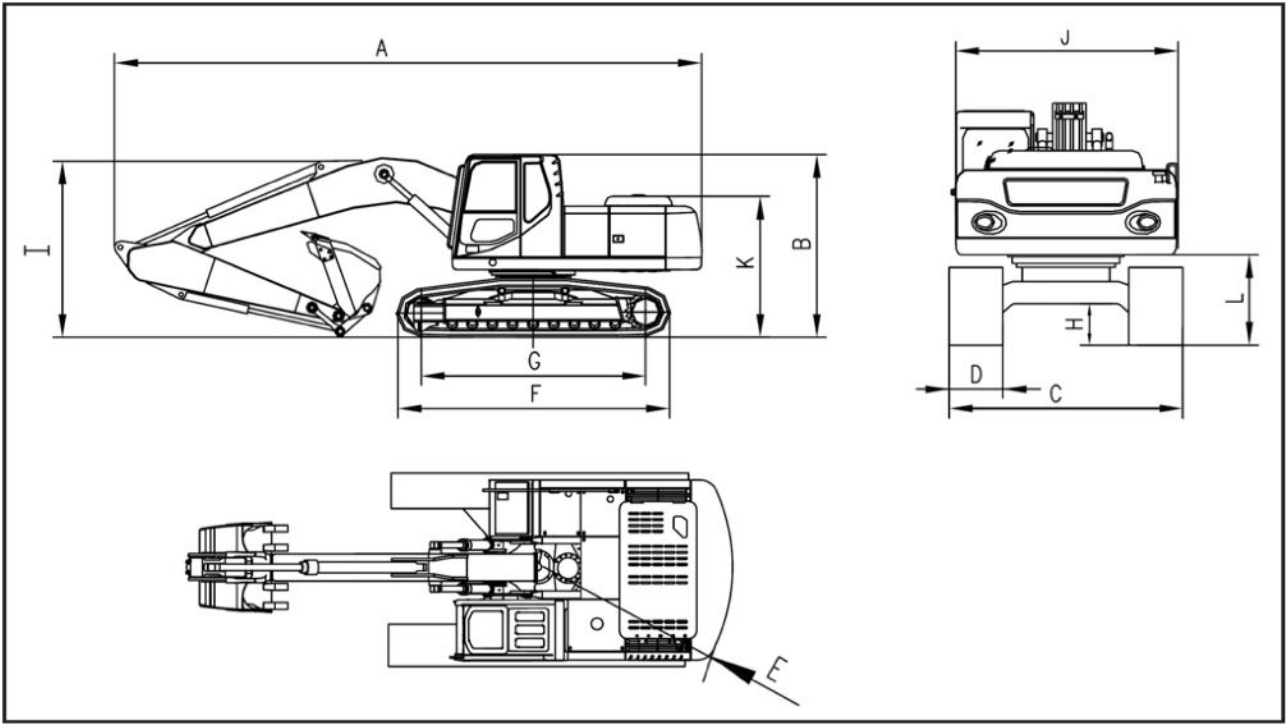

## 2. Operating parameters

Code	Item	Unit	YC310LC-8	YC360LC-8
			895	896
<b>A</b>	Maximum digging height	Mm	10190	10320
<b>B</b>	Maximum dumping height	Mm	7165	7255
<b>C</b>	Maximum digging depth	Mm	7410	7366
<b>D</b>	Maximum digging radius	Mm	10620	11095
<b>D1</b>	Maximum digging distance of ground level	Mm	10420	10900
<b>E</b>	Digging radius of the maximum digging height	Mm	6670	7280
<b>F</b>	Minimum rotation radius	Mm	3825	4224
	Maximum digging force of bucket	KN	175	200

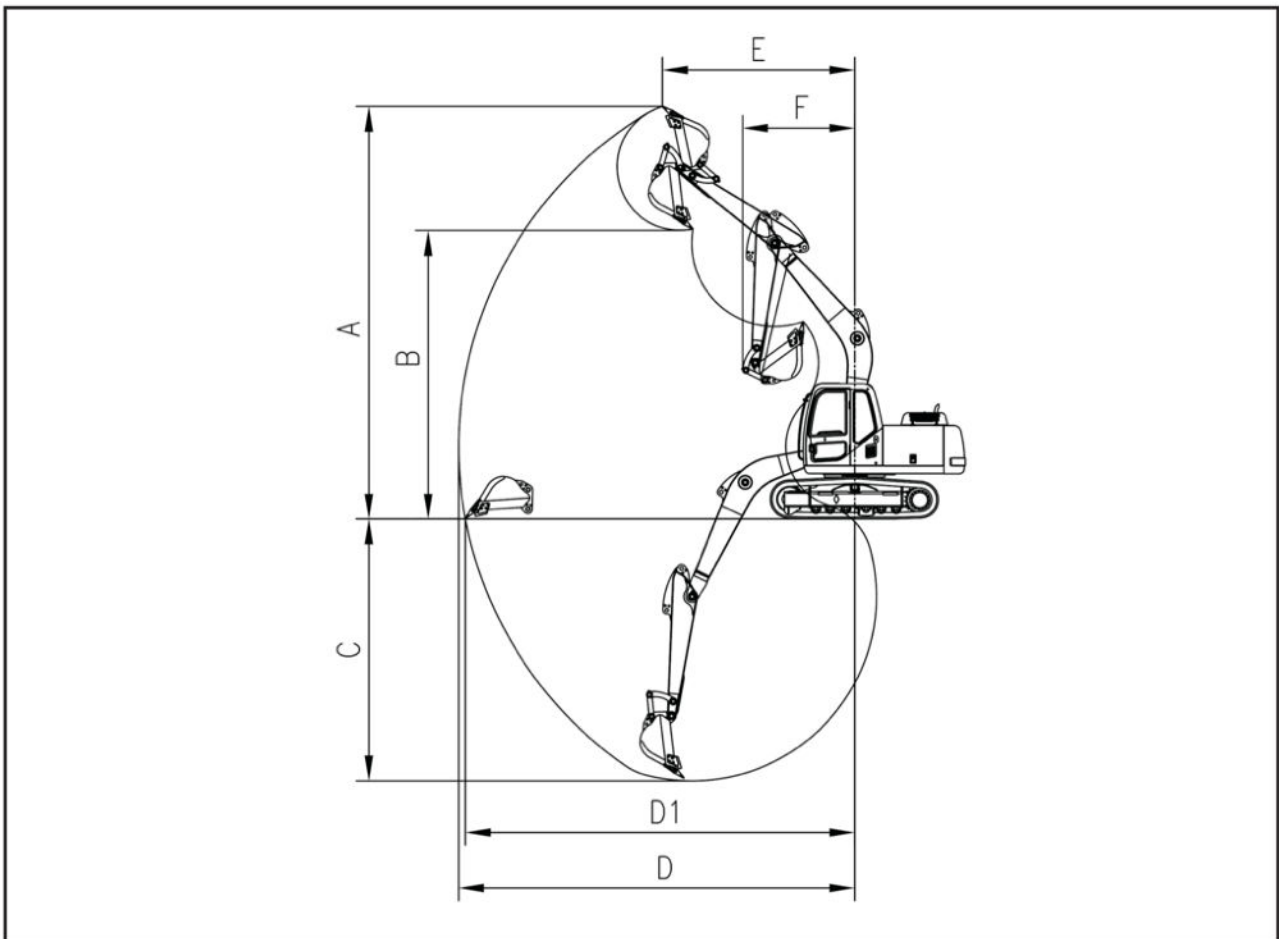

Note: when manufacturer do some change, they will not give prior notice.

### 3. Walking structure

An independence drive is by a hydraulic motor through the multi-stage planetary reducer.

	Walking speed (km/h)	Maximum traction (kn)	Climbing ability
High speed	5.2	225	70%
Low speed	3.1	347	

### 4. Bucket

	895	896
Bucket Capacity (m <sup>3</sup> )	1.43	1.63
Bucket width(mm )	1463	1605
Weight(kg )		
Bucket teeth	5	5

### 5. Bucket work environment

Bucket type			895	896
Bucket Capacity(m <sup>3</sup> )			1.43	1.63
Standard boom	Standard Stick	Normal assembly	E	E

Code	A	B	C	D	E	X
The weight scope of the work object	≤1200kg/m	200kg/m~1600kg/m	1600kg/m~1800kg/m	1600kg/m~1800kg/m	1900kg/m~200kg/m	Unavailable
Soil level	Sand and silt, mud, planting soil	Light clay, small rocks, mud, planting soil with root	Loam, heavy sand, dry loess	Heavy sand, Hard loess, Clay with stones	Dense hard-loess, Light marl stone, frail shale	

## 6 Hydraulic hammer (Optional)

Type	Tower-type
Length (mm)	2823
Striking frequency (bpm)	350~600
Weight (kg)	1754

## 7. Working environment of the hydraulic hammer

Accessory Type			Tower-type
Standard boom	Standard Stick	Normal assembly	★
Heavy boom	Heavy stick	Normal assembly	★

Note: ★ mainly applying to the breaking of the higher level road(such as highways), the disruption of the municipal roads, low-rise building demolition, the breakage of the wind fossils, the second crushing of the small ore which is of the low-grade hardness.

X Unavailable

## 8. Hydraulic system

Inverted flux control hydraulic system

Main valve: imported multi-pass valve

Maximum flow of the system  
 (YC360LC-8) 2 x 260+30 (YC310LC-8) 2 x 280+30

Pressure 32.5

Return Line Oil Filters 10μm

Oil filters 150μm

## 9. Electrical system

Voltage: 24V

Battery: 2x120ah

## 10. Normal work environment

Environment temperature: -15°C~40°C



---

**Safety Regulations**

## General Safety

Follow the relevant safety regulations in this manual, and most of the accidents caused by the dangerous operation and maintenance of the machine will be avoided. Before you operate or maintain your company, please have an understanding of this manual and all of the safety information of the machine in the diagram.

The content relating to safety of this manual specifies the possible situation during the normal operation and maintenance, as well as the reasonable treatment of these situations.

The safety related content found in every chapter of the manual and the content in this chapter consist of the comprehensive guidance for the safety.

The content of the manual and safety information on the machine will not include all potential hazards and possible response measures. If the methods or actions you take are not recommended or allowed in this manual or on the machine, you are responsible for taking necessary measures to ensure safety.

In any case, you can not engage in any prohibited use or operation in this manual.

The excavator should be operated and maintained by the person who has been trained and qualified.

Before starting work, you should check the various functions of the machine. If there is something wrong, you should immediately stop the machine and find the reason. The work can be carried out only after troubleshooting.

Inspection, maintenance and repair of the machine must be in accordance with the provision in this manual, and the control personnel should operate the machine in the manipulation methods and the working scope of the machine and under the safety regulations provided in this manual.

If you are in the influence of alcohol or drugs, do not operate or maintain the machine, which will make you and the people around you in danger.

You must know the meaning of the related signals and gestures.

When you are driving this machine on the road, you must be familiar with the relevant laws and regulations of the county or territory, and strictly adhere to them.

Please operate the machine after making sure that there're no other people in the work area.

This machine is only used for digging under the normal ground conditions; please do not use it under the water, in the culverts and the explosive places, toxic environment, and other dangerous conditions.

## Safety Tips

### 1. Warning signs





In this manual, the warning signs refer to important information about safety. When you see this sign, you should carefully read the information and advice of the signs to avoid possible injury or death.

### 2. Safety warnings

This manual provides the safety precautions, identifications and description of potential hazards, and the operator should read this manual, the safety identity attached to the machine carefully before operation, maintenance, and repair of the machine, and do the work in accordance with relevant procedures.

Safety warnings of the machine are indicated by the "**Dangerous**", "**Warning**" "**Note**" and other words, whose corresponding explanations are as follows:

-  **Dangerous:** If it is not avoided, the consequence of the danger will result in death or serious injury. This word applies to only a few occasions of the most serious risk.
-  **Warning:** If it is not avoided, the consequence of the potential danger could result in death or serious injury.
-  **Note:** If it is not avoided, the consequence of the potential danger may lead to low or moderate injury. This word can also be used to prompt the unsafe operation which may lead to the personal injury.

# Safety Equipment

## 1. Protective equipments of the operators

- 1) Before the operation and maintenance, the operators must wear tight-fitting suitable overalls, helmets, shoes and other work-related safety products (such as: ear protection, gloves, protective glasses, belts, etc.).
- 2) If the operator's hair is too long, please band it, and cover up it with a helmet, which will protect your hair from being entangled in the machine.
- 3) The user must have the emergency medicine in the machine, and conduct regular inspections, if necessary, add drugs for the use when needed.
- 5) Before the operation and maintenance, you must check if all the protective equipment is functioning properly.

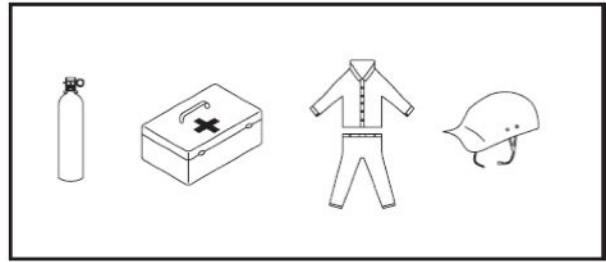

## 2. Escape hammers

Both the escape hammer and fire extinguisher are installed on the rear left column of the cab.

Escape hammers should be installed on the on the right side of the wall in the cab.

When trapped in the cab and needing escape, you should hit the glass with the escape hammer's tip against the glass until the glass is shattered. When striking, please protect your eyes and face.

When the machine is on fire, put out the fire with the fire extinguisher of the machine.

Please read the use manual of the fire extinguisher carefully and do strictly according to the manual.

Check and maintain the fire extinguisher periodically.

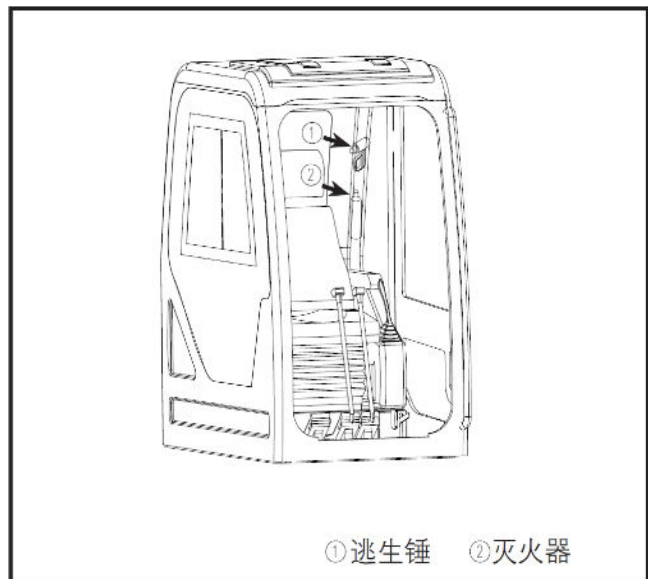

## Safety Signs



**Warning: if you cannot understand the safety signs, or the safety signs are missing, death may occur. Please replace the lost or damaged signs immediately, as well as keep the surface of the signs clean.**

Before the Operation and maintenance, repair of the machine, you must read the manual and the warning signs attached to the machine carefully to ensure that have a full understanding of its contents, and operate in accordance with relevant procedures.

Before starting the machine, you should check the identifications everyday. If they are not clear enough, please clean them.

When cleaning the identifications, you can only use cotton, water and soap, but not the organic solvents and gasoline, which may lead to the loss of the signs.

If the signs are damaged, lost or cannot be seen clear, you need to change them. If the signs are on the parts which need to be placed, you must ensure the new parts have these signs too.

Please contact the Yuchai agents to obtain a new safety signs.

### 1. Classification of the safety signs

There are two kinds of safety signs in this manual, "icon safety signs" and "text safety signs".

#### A. Icon safety signs

This kind of safety signs use graphics to represent, which are easy to understand.

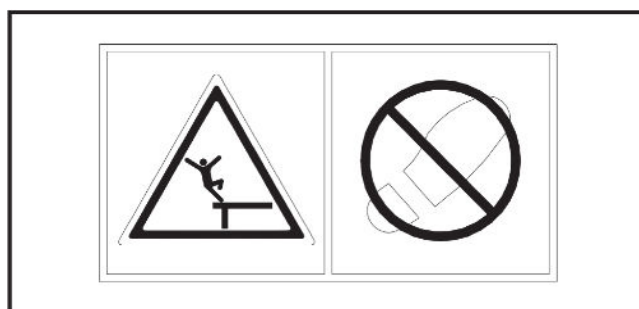

#### B. Text safety signs

This type of safety sign has the related description.



## 2. Location of the safety signs

The signs shown in the graphics are only the safety signs of all the signs, and other function signs are described in the following chapters.

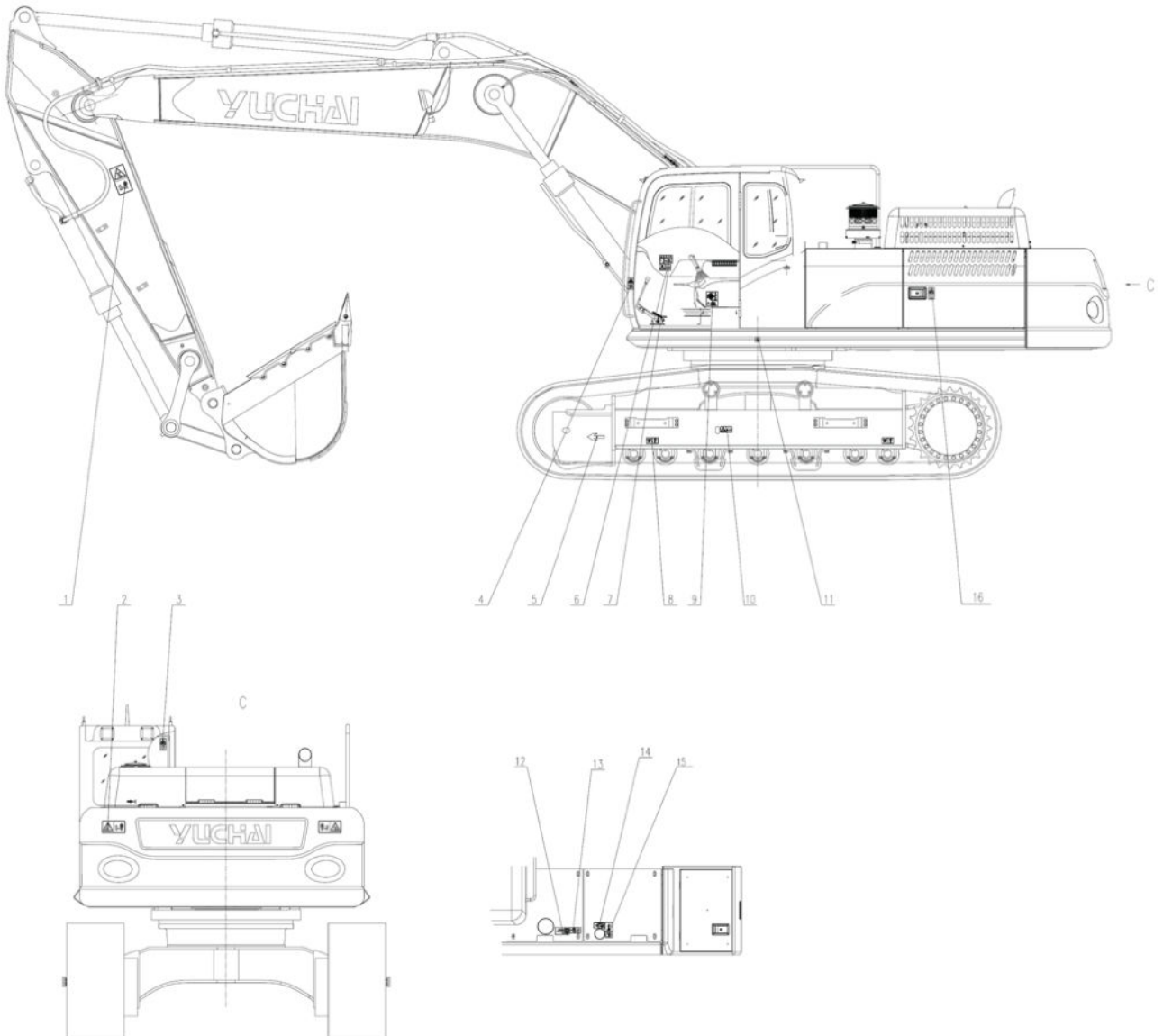

**3. Safety signs and their descriptions** **4) Please keep safe when getting up or getting down from the machine.**

**1) Be away from the working devices**



The moving working device can bring injury. Keep a safe distance from the working device.



Move slowly with facing the machine and grasping the handrails on both sides, and use the ladder and the track shoes.

**2) Safety signs 2**

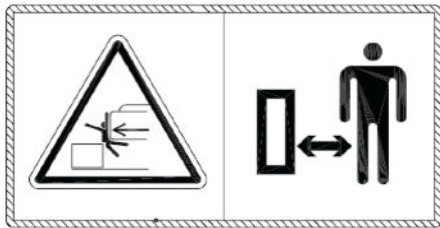

**5) March sign**

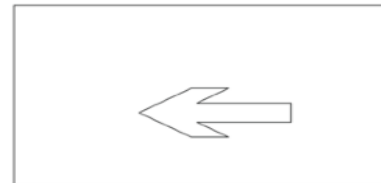

**3) Please lock it tightly after opening the window of the cab.** **6) Excavator electric shock sign**



The windows that are not locked tightly will shut back suddenly due to some external force or vibrations of the machine, which may bring personal injury.

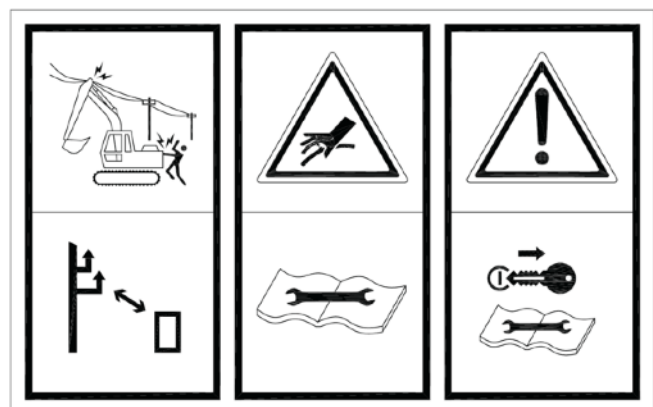

7) Sign of reading the manual

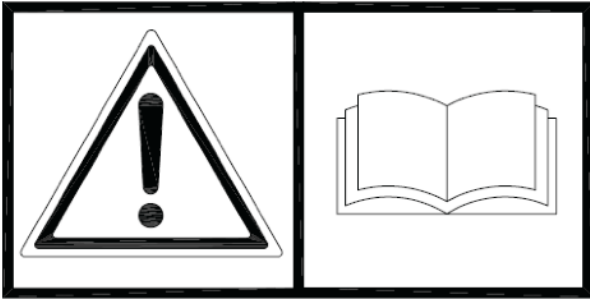

Read carefully and keep the content in your mind to prepare for contingencies.

10) When adjusting the tension of the track, pay attention to the dangerous high pressure oil that may spray out.



8) Combined hoist mark

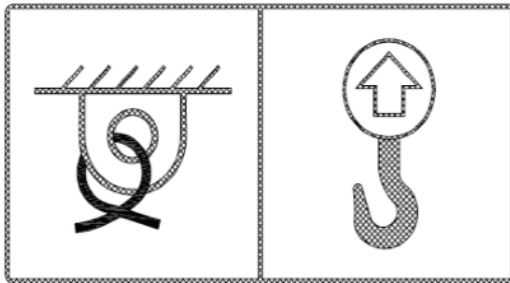

11) Sign of slewing center

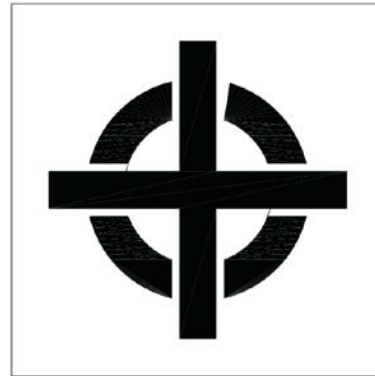

9) Oiling sign

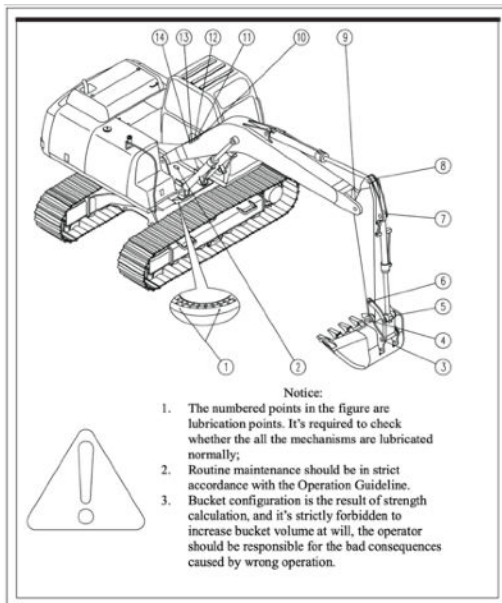

12) Sign of filling hydraulic oil

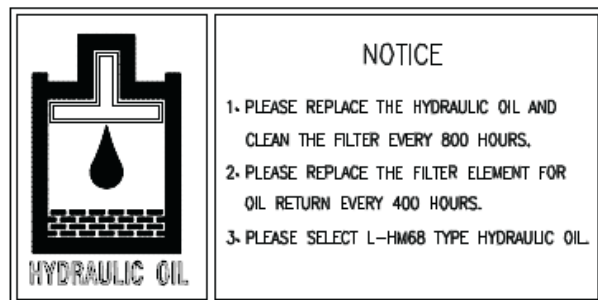



- 13) Do not open container lid of engine coolant at high temperature. 15) Sign of filling fuel



There is high pressure in high-temperature coolant. Open at this time, hot oil will squirt out, bringing personal injury. Remove the lid until it cools.

- 14) Fire prevention sign

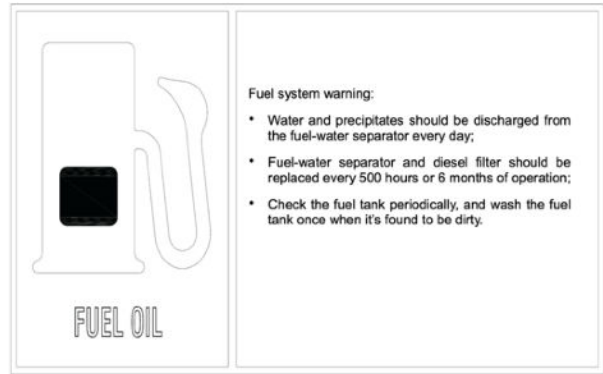

- 16) Please shut down the engine, when you want to repair and adjust the machine.



- 17) Locking sign

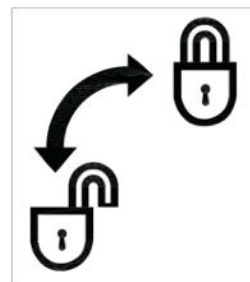

The left control box should be locked.

18) Mind the high temperature components like engine, water tank and muffler as well as engine fan that may cause personal injuries.



Do not touch directly. Repair these components after stopping the machine and wait until the temperature is cooled down to a suitable temperature.

12) Be careful of personal injury caused by engine blower.

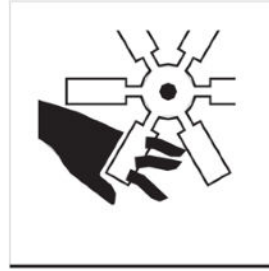

19) Sling sign

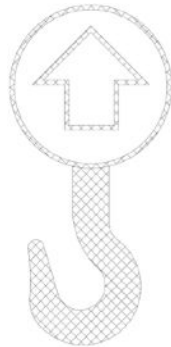

20) Throttle sign



22) Noise sign (the machine for exporting)



23) CE Sign



24) Lifting hook sign

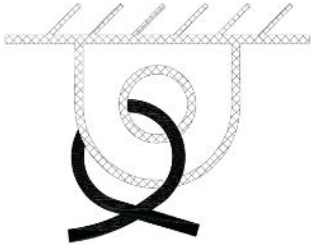

27) Sign of unlocked door

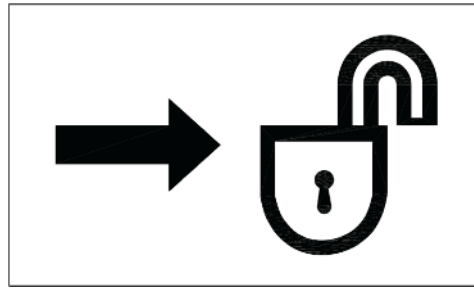

25) Do not split, drill, cut or impact the Accumulators, air spring pressure device and keep them away from open fire and heat.



These components contain high-pressure gas, improper handling of which can cause injury. Please let experienced people to handle them.

26) Binding sign

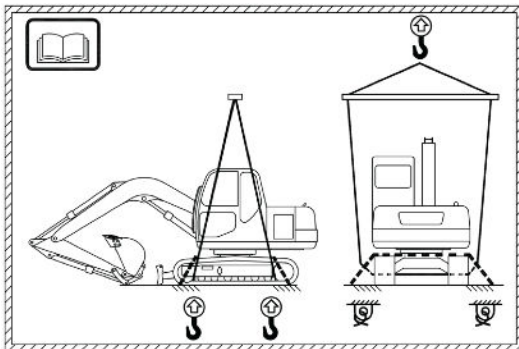

28) Escaping sign



29) Do not start the engine by starting the motor in short circuit



30) Sign of escaping direction



31) Toolbox sign

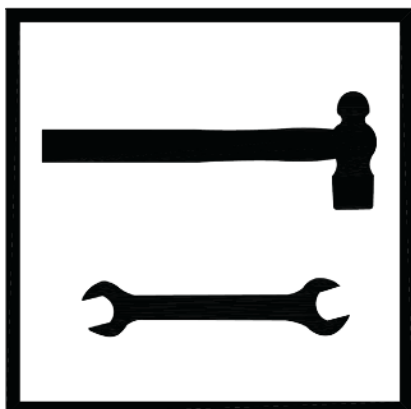

## Workplace Safety

To have a prior knowledge of your work area, you should inspect:

1. Position of the slope
2. Ditches
3. Falling or hanging objects
3. Soil conditions (soft and hard)
4. Water and marsh areas
5. Rocks and stumps
6. Boundaries of the buried foundations, pillar and the wall
7. Boundaries of the buried waste and filling soil
8. Holes, obstructions, mud or water
9. Traffic
10. Thick dust, smoke and fog
11. Exact location of the buried or suspended the lines of electricity, gas, telephone, water, sewage and other utility lines. If necessary, please let the unity companies mark, shut down or relocate these facilities before starting work.

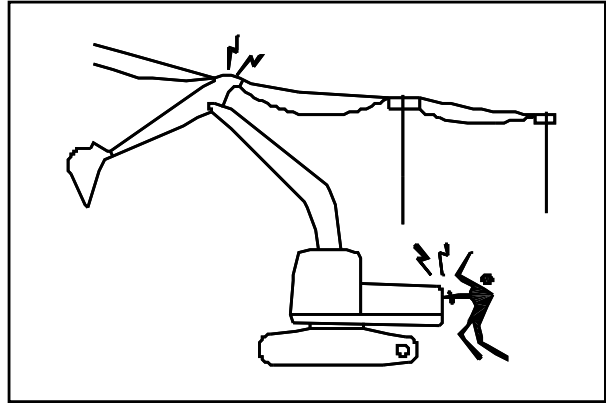

**Warning: Please contact the local utility service systems and departments before the start of digging project.**

12. When working inside the building, please know clearly the clearance of the head, porch, and aisle and so on, as well as the load-bearing capacity of the tunnel and floor. The things you do not know may hurt you. Indoor operations must have adequate ventilation.
13. Know the precise distance between the cable, telephone and the machine, the machine and the ground. If possible, it's better to cut off the power. If you cannot do this, please request the guidance of the signal member.



**Warning: Touching or approaching the power or the machine connected with the power can cause electric shock. Do not let any part of the machine close to the air supply lines, unless the necessary safety precautions have been taken. Be careful please.**

14. Make sure that keep the machine the statutory minimum distance from the underground gas pipes, cables, telephone lines and water pipes.



**Warning: If you look inside through the damaged cable, the cut fiber can seriously hurt your eyes.**

15. Do not operate this machine in the culvert or under the ground.
16. Do not operate this machine where there are hazardous chemical substances.
17. Do not operate this machine in the explosive place.

## Safe Operation



**Warning:** Before operating the machine, you must wear seatbelts and honk. After confirming there is nobody around the workplace, you can start your work.

### 1. Start the engine

#### A. Safety rules of starting the engine

- 1) You must honk for a warning before starting the engine.
- 2) Do not allow other people on the machine except the operator.
- 3) Operation can only be allowed on the seat.
- 4) Do not start the engine through starting the motor by the short circuit.
- 5) Warm up the machine under the cold weather.

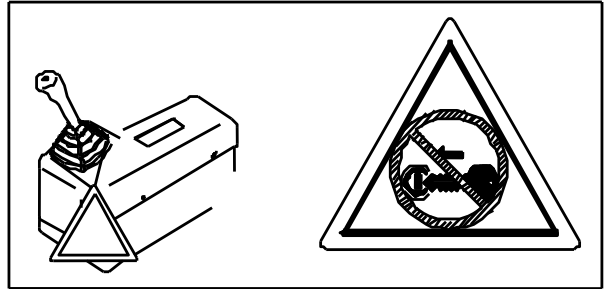

**Warning:** 1. When the sign of prohibiting engine start is hanging on the manipulation handle, the start of the engine is not allowed.

#### B. After starting the engine

After starting the engine, the following items must be checked:

- 1) If the seat belt is fastened.
- 2) If the moving parts such as work equipment, walking, rotating and working deflection devices can work properly.
- 3) If there is something wrong with the sound, vibration, smell and instrument of the machine.
- 4) If the oil and fuel leaks.

## 2. Walking and turning

- 1) The excavator must walk and work on the ground 1.5 times width than itself.
- 2) Before walking and turning, you should honk to warn the people in the work area.
- 3) Before walking operation, please turn the upper part to the right position, if the working device is at the same direction of the march sign, then push the walking rod so that the machine can go forward; if the working device is at the opposite direction of the march sign, then operate reversely.

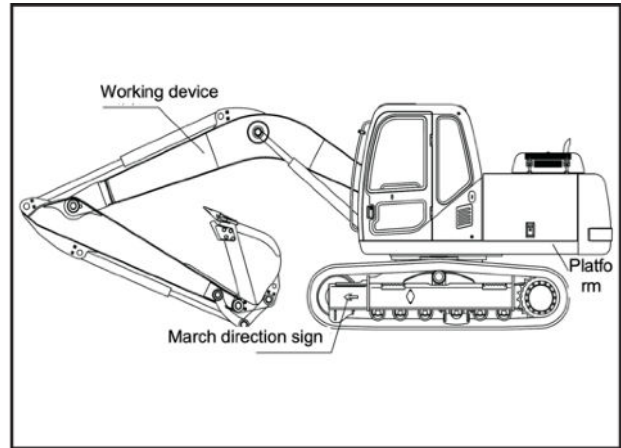

- 4) Before walking, please close and lock the door of the cab. The cab windows, overturn windows and sunroof are allowed to be open, but must be locked.
- 5) When the machine is turning or going back, if the rear area cannot be seen, a signal commander must be there.

- **Safety rules when walking**

- 1) When walking on the flat road, you must lower the boom to maintain the best position of the gravity, with a 40-50cm distance between the floor of the bucket and the ground.

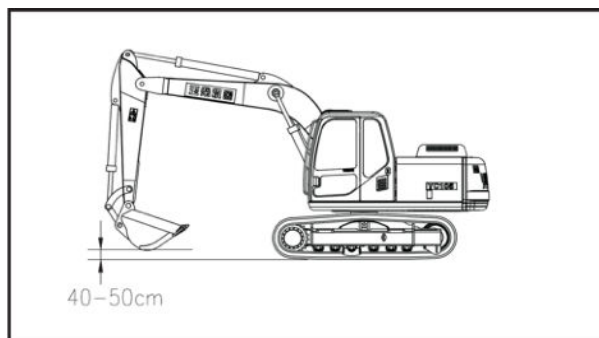

- 2) When walking on the rough, uneven road, the walking speed should be low and do not shift suddenly, or the machine may turnover, causing a danger to the personal safety.
- 3) The machine cannot walk on the uneven road with obstacles on one side, which may make it overturn.

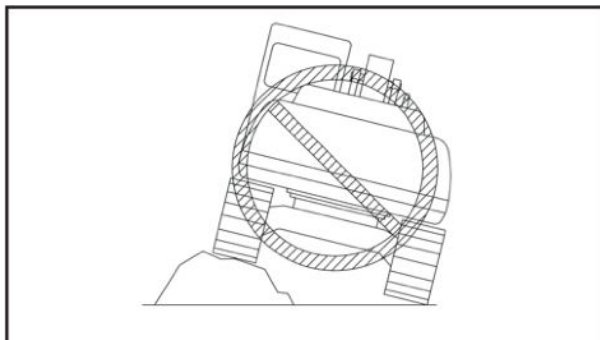



- 4) When the machine is walking or in operation, it must keep a safe distance with people, buildings and other machines to prevent access to them.
- 5) When walking through the limited high places such as the underground tunnels, under bridges or wires, make sure that there is someone to command with gesture, and keep a safe distance with the commander.
- 6) When going downhill or uphill, the platform must be locked.
- 7) When going through the bridge, building or supports, you should first confirm whether they are sufficient to support the weight of the machine.
- 8) Before walking on the road, you should first consult the local traffic management department to get permission.

### 3. Walking or working on slopes

It is very dangerous for excavators to walk or work on the slopes. You must be careful enough.

- 1) It is recommended not to go downhill or uphill on the longer slope whose angle is more than 20°.
- 2) When the machine is working, especially going downhill or uphill, please keep your belt tied tightly.
- 3) When the excavator is going uphill, keep the driving wheel in the below, lift the blade and make the moving boom, stick fully extended and parallel to the slope, with a distance of 20-30cm between the bucket teeth and the ground, and have the platform locked, then the machine can go uphill with a low speed.

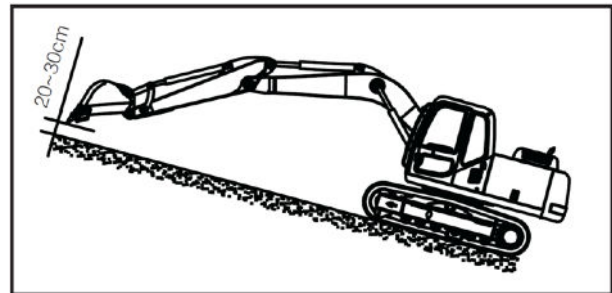

- 4) When the excavator is going downhill, keep the driving wheel in the above, lift the blade and make the moving boom, stick fully extended and parallel to the slope, with a distance of 20-30cm between the bucket teeth and the ground, and have the platform locked, then the machine can go downhill with a low speed.

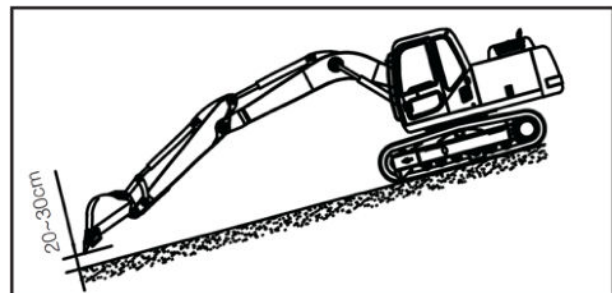

- 5) Do not turn on slopes or cross the slope. Before go uphill, you should first go downhill to a flat place to change the position of the machine.

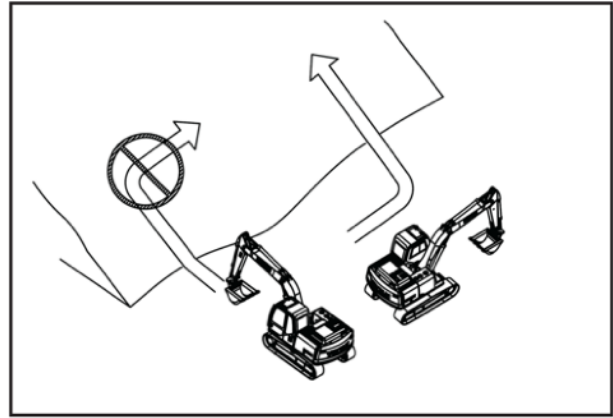

- 6) When working on the slope, it must start in the higher place, and gradually dig in the downhill direction, with the blade in the back, and the dumping position is in the uphill direction.

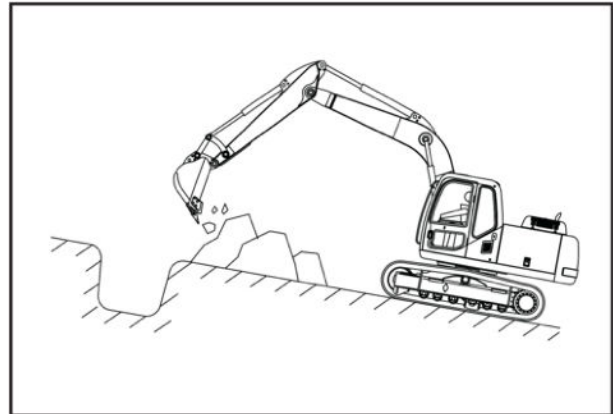

- 7) Please walk on the grass, leaves or wet steel in a low speed; because even the slope is mall, the machine also has the danger of slipping.
- 8) Do not turn sharply when going downhill or uphill, otherwise the machine will overturn.
- 9) When parking the machine on the slope, the front blade must be inserted into the soil, and the bucket must be put down to insert into the oil. After it is stable, you can stop the engine and the driver can get off the machine.

 **Dangerous**

**It is very dangerous to stop the machine on the slope! If it is inevitable, you must be in accordance with the following: if the engine stalls on the slope, please immediately lower the blade and bucket to the ground, put all the handles in place, and then restart the engine. Even a short stop on the slope, you should also lower the blade to the ground, put all the handles in place, at the same time, place enough fixed obstacles at the bottom of the tracks.**

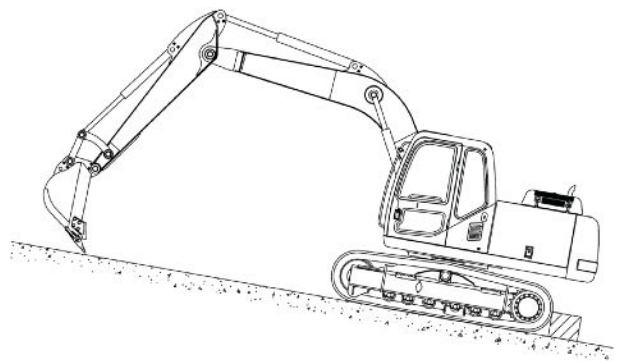



- 10) Do not walk or work on the slope whose longitudinal gradient is more than 25°.

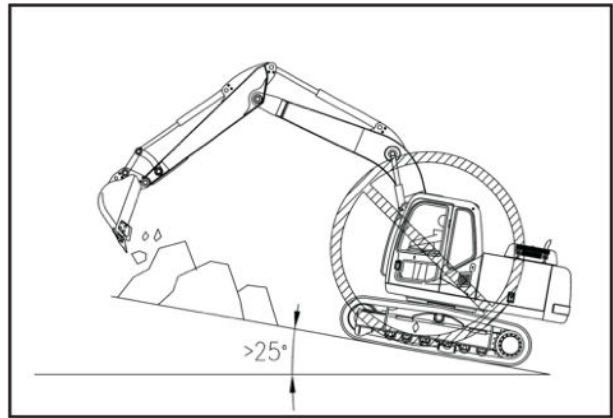

- 11) Do not walk or work on the slope whose horizontal gradient is more than 15°

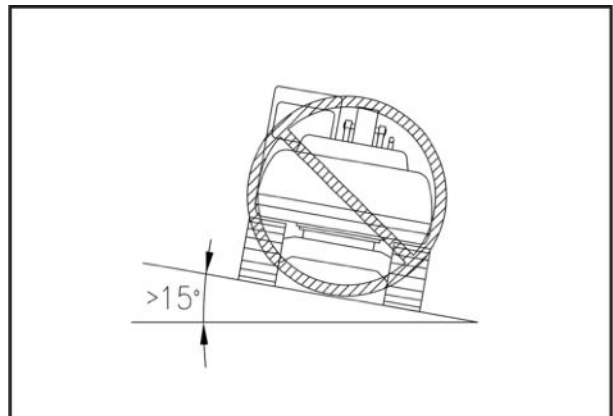

- 12) Try to keep the balance of the machine, and do not walk on the rocks or over obstacles.
- 13) Do not change the direction on the slope.
- 14) Before going uphill, ensure that the engine and hydraulic oil have been warmed up correctly, otherwise, the accident may happen.
- 15) When on the slope, the two tracks are in the direction between which and the slope, the angle is  $90^\circ$ , rotation is very dangerous, and should be avoided. If it cannot be avoided, please make the bucket close to the ground, as well as to the machine, the direction of the track toward the top of the slope, and then turn the machine back in a low speed.

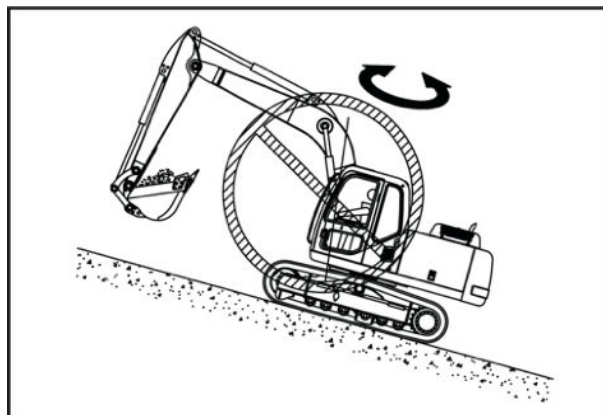

- 16) When working on the slope, the operation of the rotation and work equipment will cause danger of losing balance and overturn to the machine, which will lead to serious injury and equipment damage. Thus, when do these operations, a solid platform must be built with soil to keep the machine in the balance.

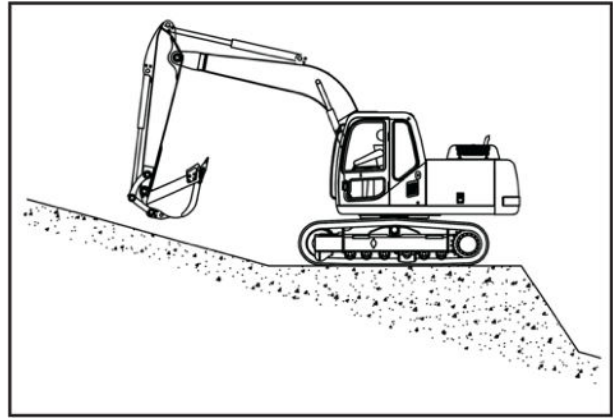

#### 4. Safe digging operations



**Warning:** The operator must remember the function of each stick, to avoid malfunction.



**Warning:** The improper use of the excavator may lead to slipping and overturn. Keeping this section in mind will play a key role in ensuring your personal safety.

- 1) Before working, the people without fixed duties should be cleared out of the workplace.
- 2) Confirm the workplace can fully support the machine, and then the machine can enter.
- 3) Before the operation, the two tracks of the excavator should be kept in the same level as possible as they can.
- 4) Make sure there are no cables, gas pipes or water pipes. If there are, please know clearly their exact location, then the digging can be carried out.

- 5) When the machine in the reverse operation (such as trenching, etc.), you should observe if the shift line is flat and if there are any obstacles. The shift should be in the safe conditions; otherwise, the machine may be caused to overturn.

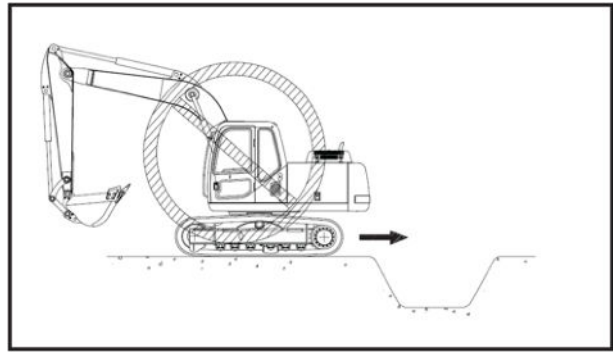

- 6) When the bucket subjects to a special resistance on the ground do not walk or turn otherwise the machine may be damaged.

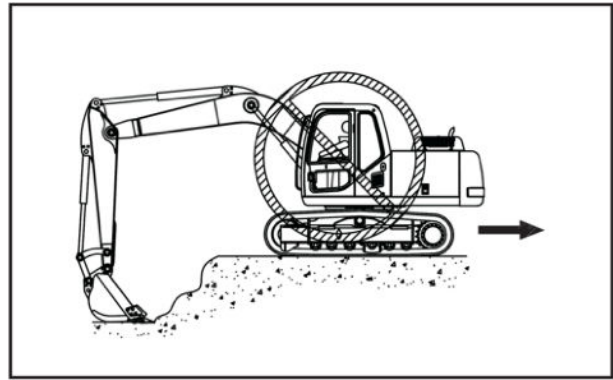

- 7) In the operation, if the hydraulic cylinder is controlled to the end of the travel, the force will act to the spacing ring inside the hydraulic cylinder, which will reduce the life of the machine. To prevent this happening, when operating the hydraulic cylinder, a small margin should be kept all the time.
- 8) When digging, the moving boom bottom and the soft arm of the bucket cylinder should be avoided to touch the ground.
- 9) When manipulate the machine, the other objects should be avoided to touch the moving boom, stick, bucket, cab.
- 10) When the machine is rotating, touching the engine bonnet and the weight blocks in the rear should be avoided.
- 11) When lowering the boom, do not stop suddenly to avoid damage to the machine and improve the safety of the work.

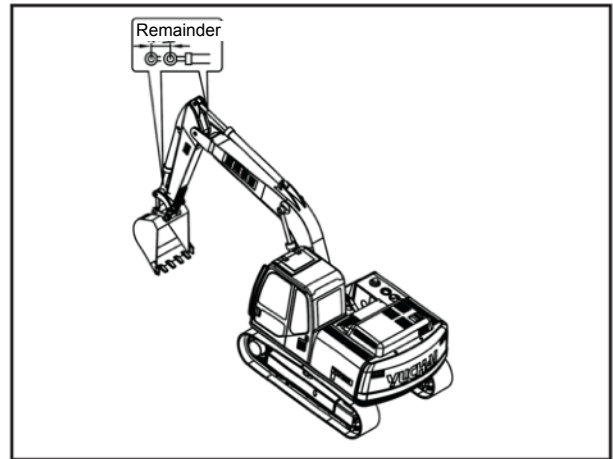



12) Do not dig towards the machine body.

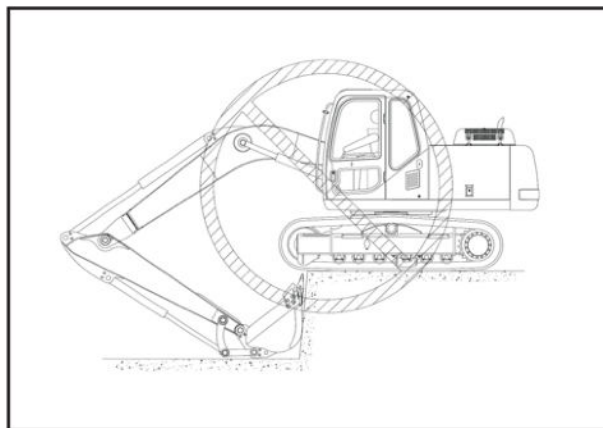

- 13) If the tracks are not on the ground, do not dig, otherwise the structure of the machine may be damaged.

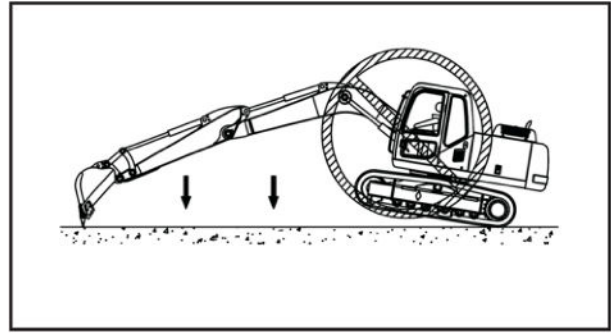

- 14) Do not increase the machine's digging force by its own weight.

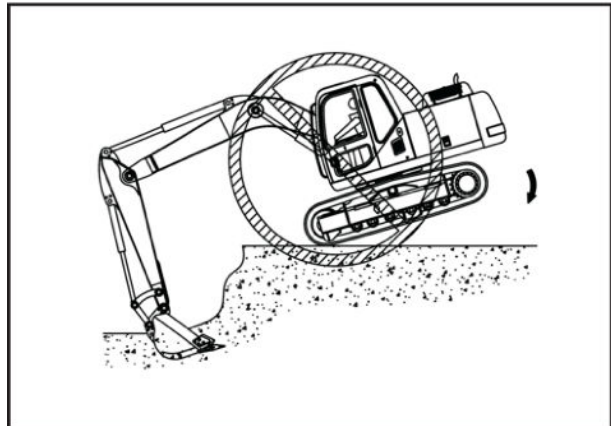

- 15) Do not regard the falling-down force of the bucket as a hands-ho, a breaker, or a hammer, which make the rear of the machine withstand excessive force. It is very dangerous and will cause damage to the machine.

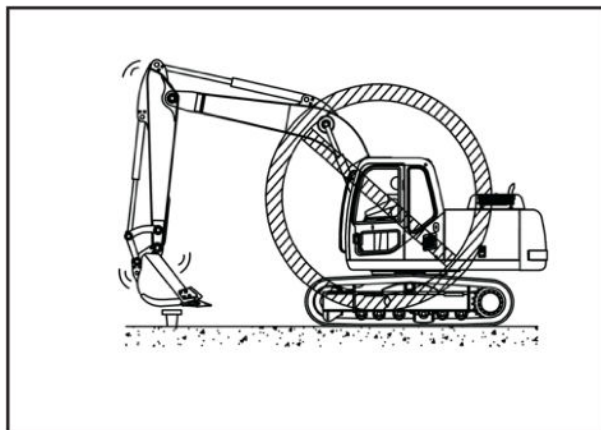

- 16) Do not build the flat road with the bucket too much, otherwise the machine may be damaged because of the overload operation of the components.

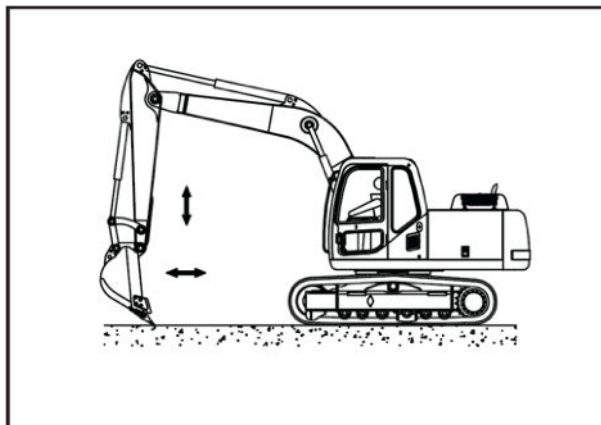

- 17) Do not use the falling-down force of the machine to dig, otherwise the machine will be damaged.

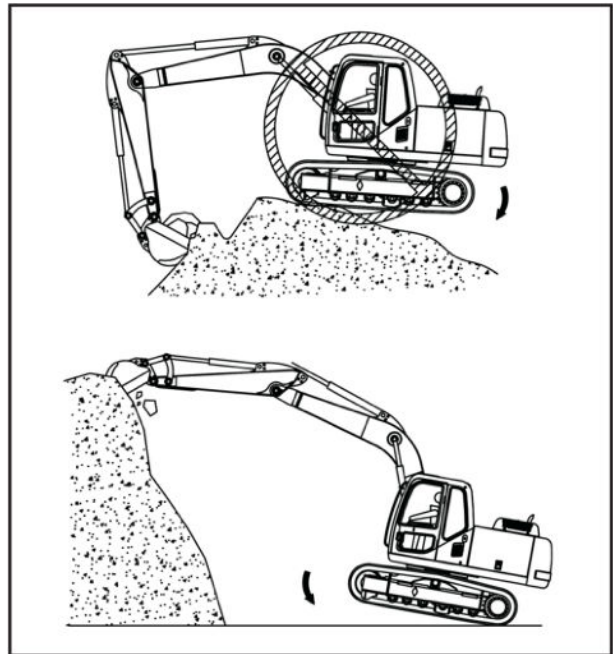

- 18) Do not use a rotary force to compact the soil, destruct the mound, or damage the wall. When rotating, do not let the bucket teeth into the soil, which will damage the machine.

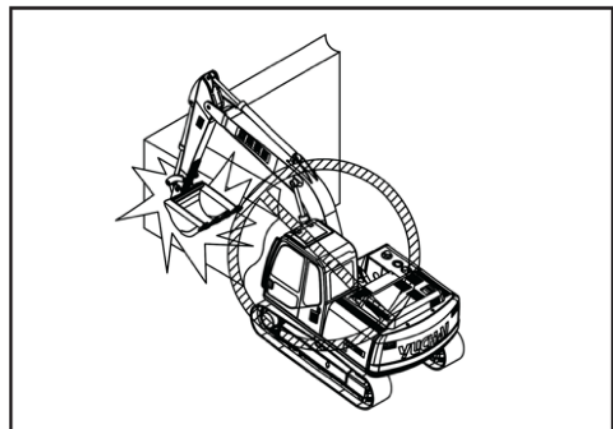

- 19) Do not use the walking force to dig with the bucket inserted into the soil, which will make the rear of the machine bear too heavy force.

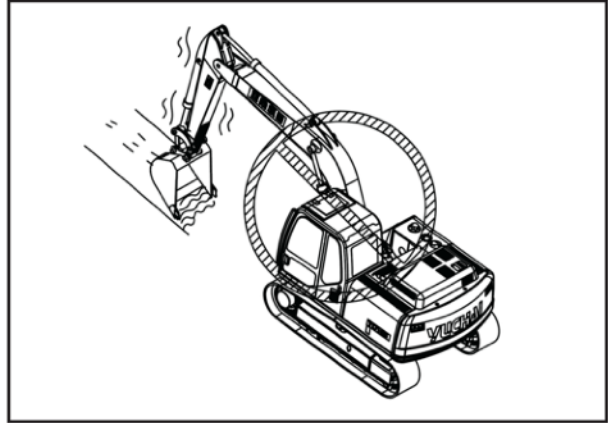

- 20) Do not dig the working surface below the vacant part. There will be danger of rock falling or the collapse of the vacant part, which will hit the machine.

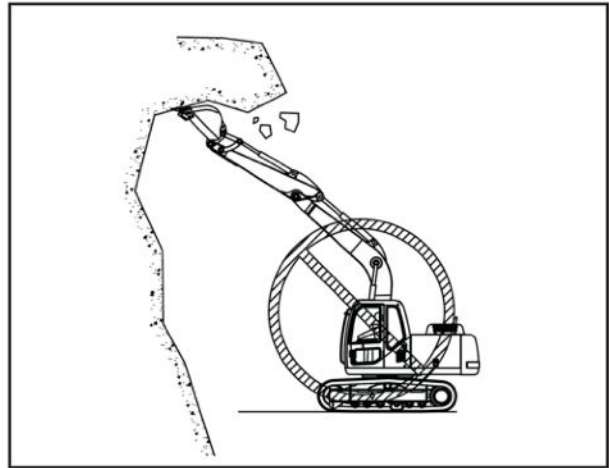

- 21) If the machine is working where there is danger of the objects falling or the splashing, the equipment of preventing the falling of the objects or splashing should be fitted

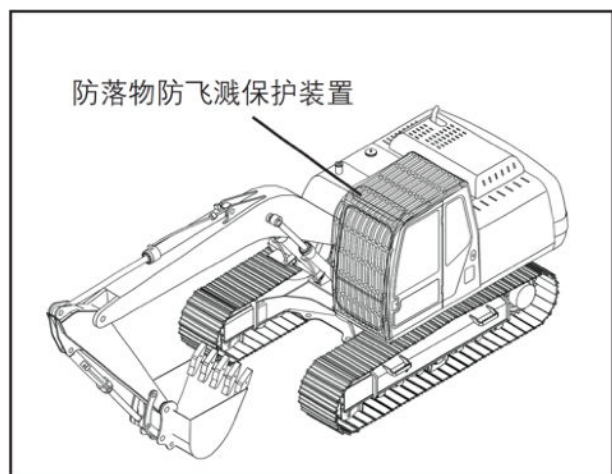

- 22) Do not operate the machine on the soft or swamp road.

23) Do not use the excavator to drag other devices or objects.

## 5. Anti-overnturn, anti-slipping in the operation and the treatment



- Warnings:**
- 1) when you have to turn on the slope, it is only sweeping turn. When the machine is to turn right, the boom stick should be toward the left with the bucket about 30cm from the ground, and the platform should be locked. And vice versa.
  - 2) When the machine is slipping, the blade and the bucket should be pushed down to the underground.
  - 3) When the machine is overturned, the driver must not jump off the machine, but should firmly grasp the handrail in the cab. Jumping is likely to cause casualties.

In the following conditions, the machine is easy to overturn. So please be sure to avoid these conditions.

- 1) When the machine is shifting on the uneven ground, with one track higher and the other lower, or more than half of one track hanging in the air.
- 2) When one track is touching the loosen soil and the other is touching the compacted soil.
- 3) When the underground of one side of the machine is cave or mud pit.

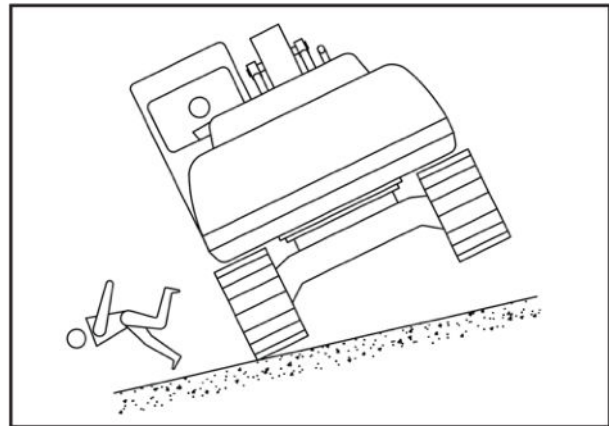

- 4) When walking and working on the slope whose vertical gradient is greater than 25°, as well as the unloading of the heavy objects is in the downhill direction.
- 5) When walking and working on the slope whose Horizontal gradient is greater than 15°, as well as the unloading of the heavy objects is in the downhill direction.
- 6) On the slope, the angle of the two tracks and the slope is 90°, and the rotation of the platform is greater than 90°.
- 7) When working on the slope, the machine is turning suddenly, the platform is rotating quickly or the machine is stopped in a sudden.
- 8) When on the slope, the machine is swinging 180° towards the downhill.
- 9) When in a reverse operation (trenching, etc), the shift road is rugged.
- 10) When the machine is digging to below the machine body.
- 11) When walking on the frozen ground.



12) If there is engine oil or lubricant oil on the two tracks, then the machine is prone to slipping.

## **6. Shut down the machine**

Please refer to the section of “parking machines” in this Chapter

## Transport and Handling Machine

Excavator transport (handling) should strictly abide by safety principles.

- When transporting excavator, abide by the rules or good habits of safe transport (handling) in national and local industry.
- When transporting excavator, it's strictly forbidden to take any personnel or other items and it's strictly forbidden man-machine mixed and mix-carried.
- When handling excavator, within action radius of crane arm including suspended object, it's strictly forbidden any person or items which may interfere handling.
- When handling excavator, within walking domain of excavator handled including rotary range, it's strictly forbidden any person or items which may interfere handling.
- Except that excavator is lifted or excavator enters directly from wharf, two access boards with enough strength are used for transport vehicles. Tilt angle of access board should be less than  $15^\circ$ . The length of slope is 3.5 times larger than the height. The width of access board is 1.2 to 1.5 times than the width of track.
- Before sliding up and down, positioning handle of rotary platform should be put down to prevent platform rotation.
- When sliding up and down, except operating walking handle, any other handles should not be permitted to wrench.
- Handle the machine on the solid and flat surface.
- When the machine is driving on the road, clearance banner, lights and warning signs should be ready, and ensure that other people can see these signs, and ensure that vehicles behind can see the sign saying "Go slow".
- Track-type machine may damage road surface. There are some restrictions when driving on the road, therefore when driving on these roads truck transportation machine should be used.

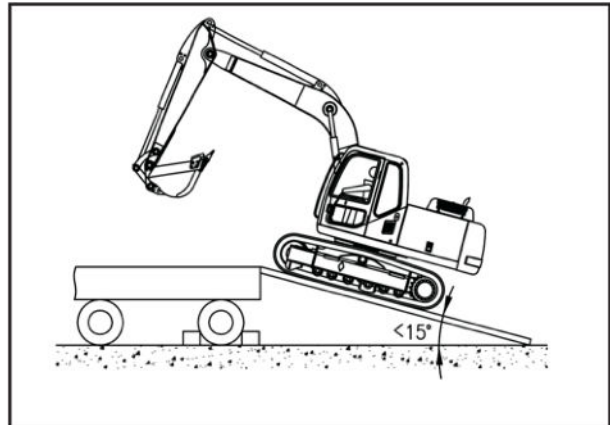

## Stop the Machine and the Maintenance



**Warning: When carrying out any repairs on the machine, you must hang the warning signs of “Do not operate” on the operation handle.**

- The excavator must stop on the solid and flat ground.
- After the machine stops steadily, the bucket must be lowered to the ground, the engine must be idled for 3minutes, and then shut the machine down and pull the key of the switch.
- Relief the pressure of all the hydraulic systems.
- When you are forced to shut down the machine on the slop, the enough barriers should be set in both down direction of the two tracks.
- Make sure that keep a certain distance between the machine and other machines, when it is stopped.
- For the repair of the electric system or electric welding, it needs to disassemble the negative cable of the battery to prevent the circulation of electrical current.
- If the repayment needs to support the machine or its accessories, please support them firmly. Do not work under the support of a single jack.
- After the machine is starting, do not lubricate or repair, and do not make the hands and feet, as well as clothing touch the power rotating parts.
- If the repair is under the running of the engine, the machine must be watched by someone.
- Do not put any articles in the pocket, which may drop onto the moving components.
- The splashing of the high-pressure liquid will hurt your eyes and skin, which should be avoided in the repair.
- Clear all the debris inside the machine, to protect against possible malfunction, which will cause injury to the personnel or damage to the machine.
- Make proper disposal of the waste liquid. Do not put the oil into the ground, drains, pond or lake. Discharge of oil, fuel, antifreeze liquid and other hazardous waste and processing of plastic, battery should comply with environmental regulations.

## Fire Prevention, Explosion-proof and Anti-poisoning

- The excavator should be avoided to contact with the electric wires when it is in transportation, walking or digging, otherwise serious injury and death may be caused.
- Please always check the appliance and circuit of the machine. If any damage, injury, or aging are found, they must be changed promptly to avoid the short circuit that can cause a fire.
- Maintain the wire connectors clean and fixed. You should have a daily check of the electric wires, tighten the loosen fittings and repair the damaged wires.
- Do not place the flammable and explosive items inside the machine to prevent the fire.
- When refueling, the engine must be stopped. You should refuel in a place far away from the fire source, and cannot leave the machine.

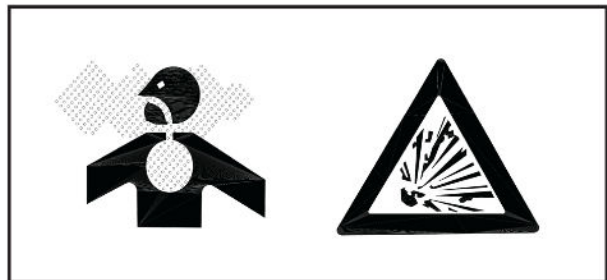

- When refueling, do not let the fuel overflow the overheating surface or the components of the electric system.
- After refueling, wipe the spilled fuel or oil, and tighten the cover of the fuel tank and the oil tank.
- Promptly clear the leaves, wood, paper and other combustibles accumulating or stuck in the engine, exhaust pipe, muffler and engine compartment.
- Do not place the oil-soaked rag inside the machine to avoid spontaneous combustion and fire.
- Configure the fire barrel inside the machine, and put it in place to get readily.
- Welding the machine must be carried out in the condition that the hydraulic tubing and the fuel line have been isolated.
- Prevent fires caused by hydraulic piping: Check all the hoses, clamp tube and shield, as well as check if the cushion is fixed firmly, the loose of which will cause vibration and friction with other parts in the operation, leading to the damage of the hose, oil-spraying of the high pressure oil and even a fire or serious injury.
- Make the battery away from the fire source and avoid the high temperature, otherwise an explosion may be caused.
- If the cab of the excavator is sealed, the tightness of the middle partition should be checked to prevent the engine exhaust into the cab, which will make the driver poisoned.
- Never work in a poorly ventilated work area to prevent the choking of the driver.
- In case of fire, do not put out the fire with water, but the powder fire extinguishers or sand. You can also use the cover or tarpaulin to cover the fire off.

## Battery

### General safety of battery

Battery electrolyte contains sulfuric acid, which will produce flammable and explosive hydrogen gas. Erroneous operation will result in serious injury or fire. Therefore, we must observe the following precautions:

- The battery is equipped with the battery charge status indicator on its cover. When the indicator shows green, the battery can be used normally. When the indicator shows black, the battery should be promptly charged, and when the indicator shows white, the battery should be replaced immediately.
- When operating the battery, you must wear safety glasses and rubber gloves.
- Do not smoke or use open flames near the battery.
- If the glasses, clothes or skin are splashed with sulfuric acid, rinse immediately with plenty of water and seek medical care immediately.
- Before operating the battery, the key switch must be turned to the position "OFF".
- Check the electrolyte level with a flashlight. When checking, please turn off the engine.
- Expansion of the end of the closed battery shows that the battery has been frozen, and you cannot charge the battery connect it with the engine. Expansion of the end of the closed battery shows that the battery has been frozen, and you cannot charge the battery connect it with the engine. The frozen battery may not be heated up above 15°C, otherwise it may explode.

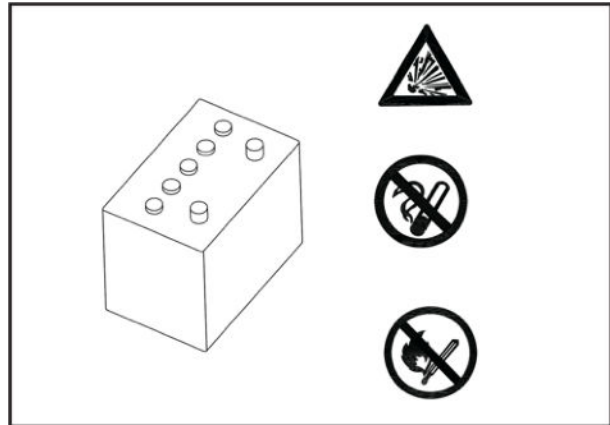

### Anti-explosion of batteries



**Warning: Spark or flame can cause explosion of the hydrogen inside the battery. To prevent explosions from occurring, please note:**

- 1) **When disconnecting the battery cables, you should firstly cut off a cathode (-) cable;**
- 2) **When connecting the battery cable, you should finally connect the cathode (-) cable;**
- 3) **You cannot connect the terminal of the battery with metal components in a short circuit;**
- 4) **You cannot weld, grind, or smoke in the vicinity of the battery.**

Because of the risk of spark, you must do according to the following steps:

- Make the battery securely mounted to the determined position.
- Do not allow tools or other metal contact between the battery terminals. Do not leave the tools or other metal objects near the battery.
- Connect or disconnect positive pole and negative pole of the battery in the correct order. Firmly fix the battery terminals.
- When charging the battery, it will produce flammable hydrogen gas. Thus, before charging we should remove the battery from the lower body to put it in a well ventilated area and remove the battery cover.
- Tighten firmly the battery cover.

**Note: When you are repair the electrical systems or carrying out the welding operation, you should remove the negative terminal of the battery to prevent the flow of current.**

# Hydraulic System

## 1. Safety rules of high-pressure oil

There is always pressure inside the hydraulic system. When checking or replacing the pipe or the soft line, be sure to check whether the pressure within the hydraulic oil has been released. The pressure in the oil line can cause serious injury or damage. So, you must do in accordance with the following provisions:

- 1) When the pressure is within the hydraulic system, do not work for inspection or replacement.
- 2) If there is any leak in the pipe or soft line, the surrounding area is wet. So, we must check if the pipe or soft line is broken and if the hose is inflated. When checking, you should wear goggles and leather gloves.
- 3) High pressure oil leaking from the hole will penetrate the skin. If you have direct contact with it, your eyes may be blind. If you are hit by the high oil flow and the skin or eyes are injured, rinse immediately with plenty of water and seek medical care immediately



## 2. Safe operation of high-pressure hose

If the high-pressure hose leaks oil or fuel oil, it will cause a fire or failure of operations, resulting in serious injury or damage. If you find the bolt is loose, you should stop working and tighten the bolt to the specified torque. The welding of the machine cannot be carried out under the condition that the hydraulic lines (hoses) are not isolated. And stop operation to have bolts to be tightened to the specified torque. If you find any damages of the hose, please immediately stop the operation, and contact the agents of Yuchai.

If the following questions are found, the hose should be replaced:

- 1) Damage or leakage of hydraulic fittings;
- 2) Cladding frayed or broken or strengthening layer exposed;
- 3) Partially expansion of the cladding
- 4) The movable part distorted or crushed
- 5) Impurities in the cladding.

## 3. Safety rules of hydraulic oil

The hydraulic oil in the work or after work that has not cooled is of high temperature and high pressure. Before the inspection or release of oil, the oil should be cool enough that you can touch the oil cap or plug to prevent burns caused by the spraying oil or the contact with hot parts. Even if the oil has cooled, before removing the cap or plug, you should also release them slowly to drain the hydraulic pressure inside the tank.





#### 4. Releasing the pressure within the hydraulic system

When the machine is just stopped, the hydraulic oil is with high temperature and pressure. While disassembling the oil port, the oil may spray out, therefore before disassembly the oil port cover should be turned to relief the pressure inside.

- 1) Supposing the working device is not in the state shown in the diagram, you should start the engine at a low speed, extend the bucket cylinder, retract the stick cylinder, put the bucket and blade on the ground, and then shut down the engine.
- 2) Within 15seconds after turning off the engine, turn the starter switch to the "ON" position, and operate the shift level in each direction (work location, working) to release the internal pressure.

#### 5. Safe operation of the accumulator



**Warning: Accumulator is filled with nitrogen gas of high-pressure, so the improper use of it can cause explosion. You cannot remove the accumulator, drill or weld on it. Prevent the accumulator from approaching the fire source or the collision and impact. Disposal of the accumulator should be carried out by professionals.**

The machine is equipped with an accumulator as a storage device in the control pipeline, leading to a short time of operation of control line after the engine stops.

You can lower the working device with the control handle under the working of its own weight.

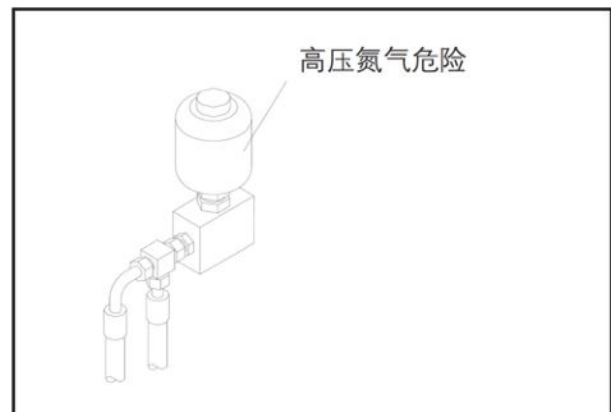

#### Releasing pressure methods of the machine control line with accumulator

- 1) Put the work device down to the ground, and then shut down the hydraulic hammer or other accessories.

- 2) Turn off the engine.
- 3) Turn the starter Switch to the "ON" position, and the circuit current will flow.
- 4) Adjust the safety locking control rod to a free position, and then control the pilot valve handle and accessories control pedal(if fitted) in all the directions to release the pressure in the control pipelines.
- 5) Shift the safety locking control rod to the locked position, to lock the operation rod and control pedal.

---

**Components Description**

## Overview of Operating Equipment

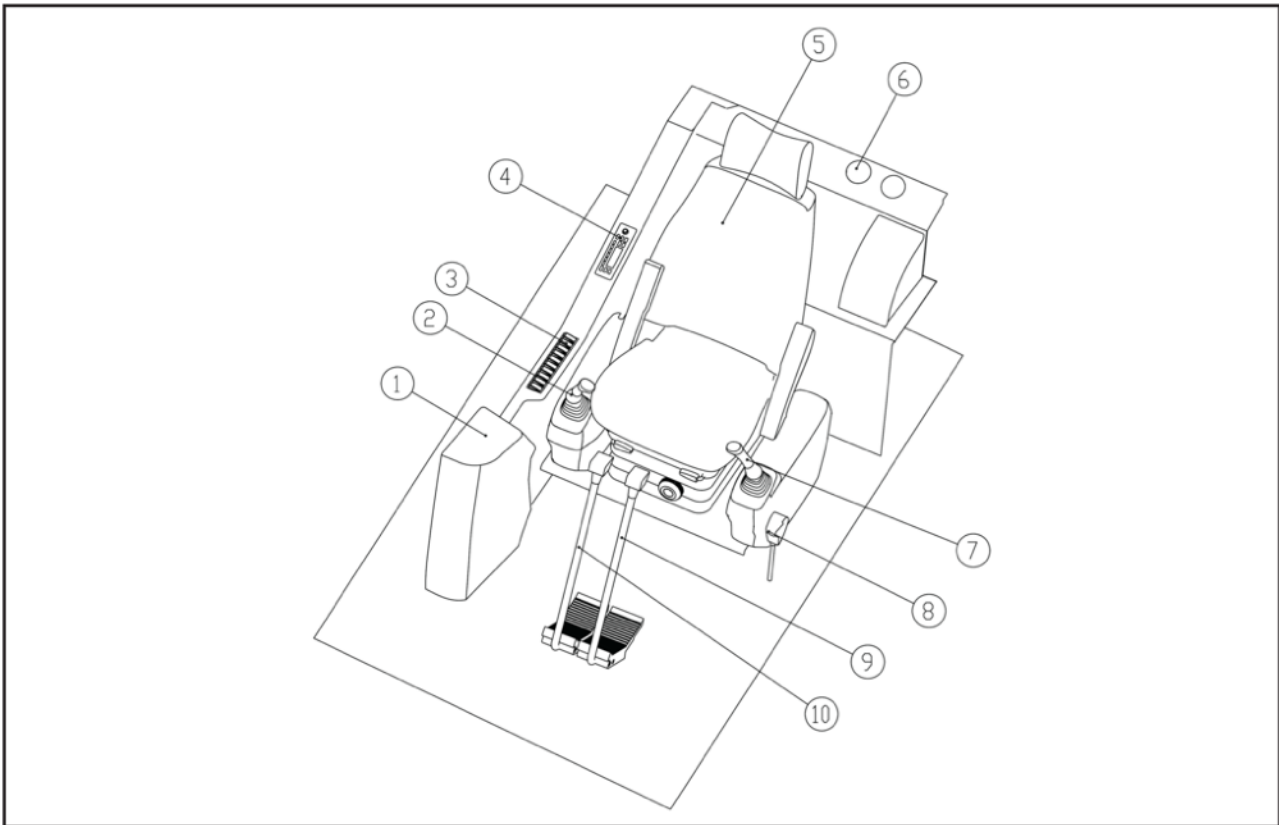

1. Monitor
2. Right pilot valve handle
3. Command control panel
4. Radio

5. Seat
6. A/C
7. Left pilot valve handle
8. Safety handle

9. Left walking control rod
10. Right walking control rod

"Yuchai Machinery"  
trade mark

Working time meter

Date

Clock

Warning

In-time work  
status

Main information  
area

Status  
information

Command  
buttons

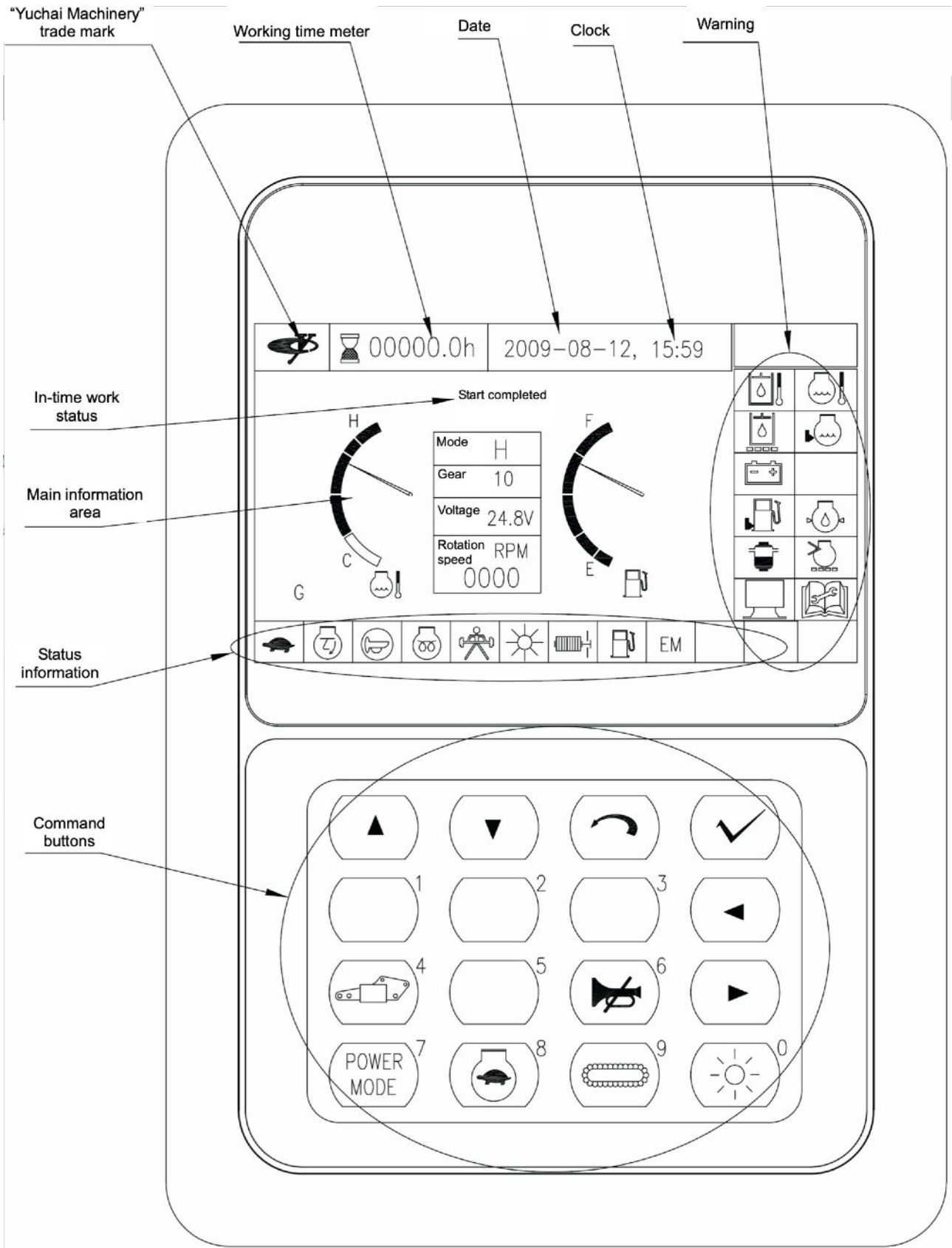

## Main Screen and Basic Operations

- Screen layout
- Working time meter and clock

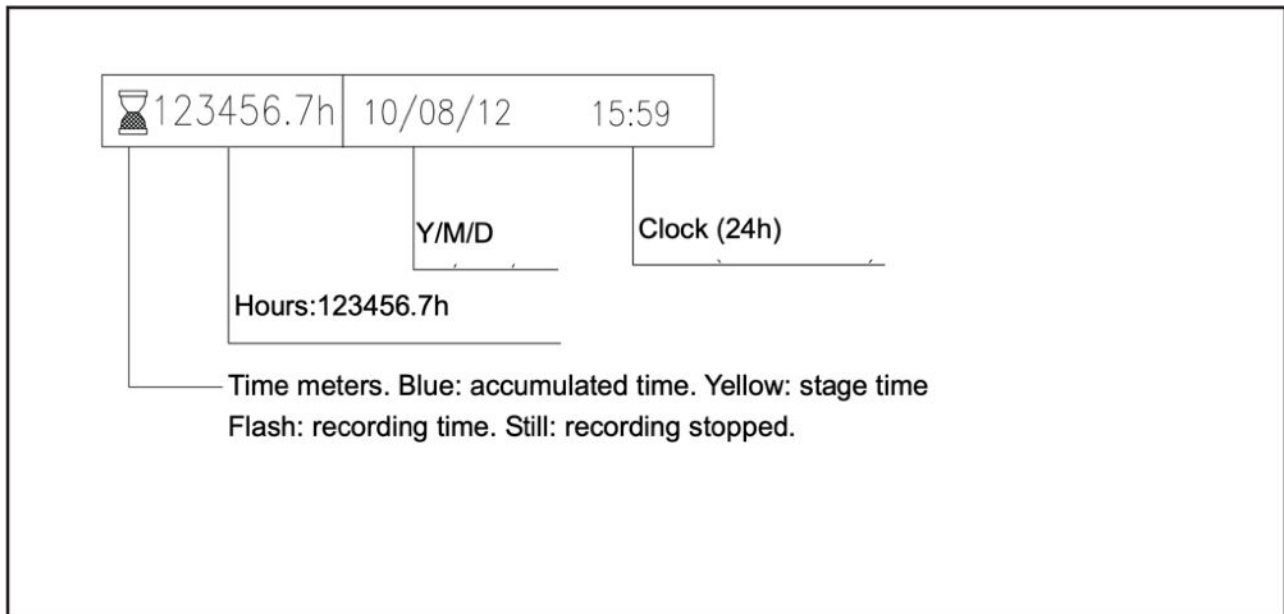

- Machine status display

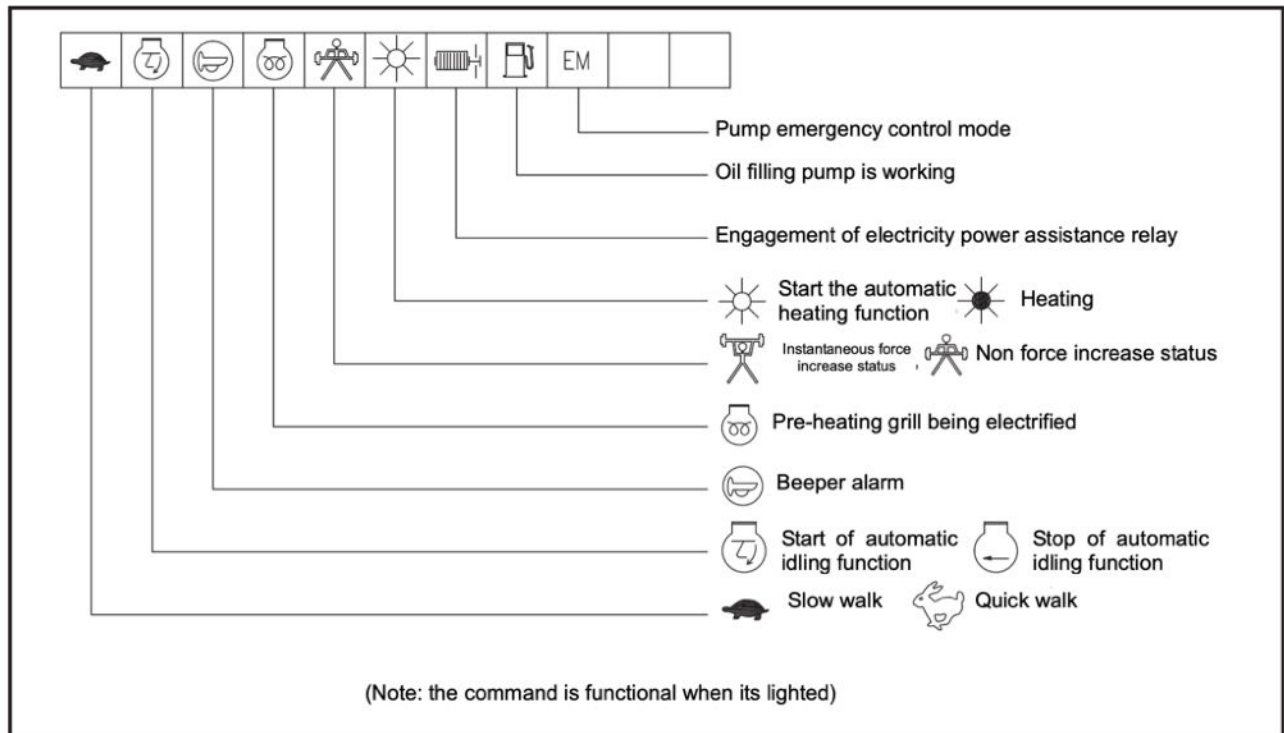

● **Machine alarm display**

			High hydraulic oil temperature alarm
			High engine cooling liquid temperature alarm
			Low engine cooling liquid level alarm (reserved)
			Outlet hydraulic oil filter blockage alarm
			System electricity power voltage alarm. It alarms when the electricity power voltage is too low or too high.
			Low fuel level alarm
			Low engine oil pressure alarm
			Engine's air filter blockage alarm
			Fuel/water separator alarm
			(Reserved)
			There's maintenance alarm information

(It's highlighted when alarmed)

● **Main screen**

In-time information

Pump emergency control mode

Mode H

Gear 10

Voltage 24.8V

Rotation speed RPM 0000

Fuel oil meter (when the fuel level is low, there's alarm in the alarming area of the machine)

Power modes: mode L, S and H

Throttle gears 1~10

Current voltage of the system, the unit is volt

Current engine rotation speed, the unit is rpm

Engine cooling liquid temperature meter (when the engine cooling liquid temperature is too high, there's alarm in the alarming area of the machine)

For the machine with GPS, this letter is shown when the GPS function is activated.

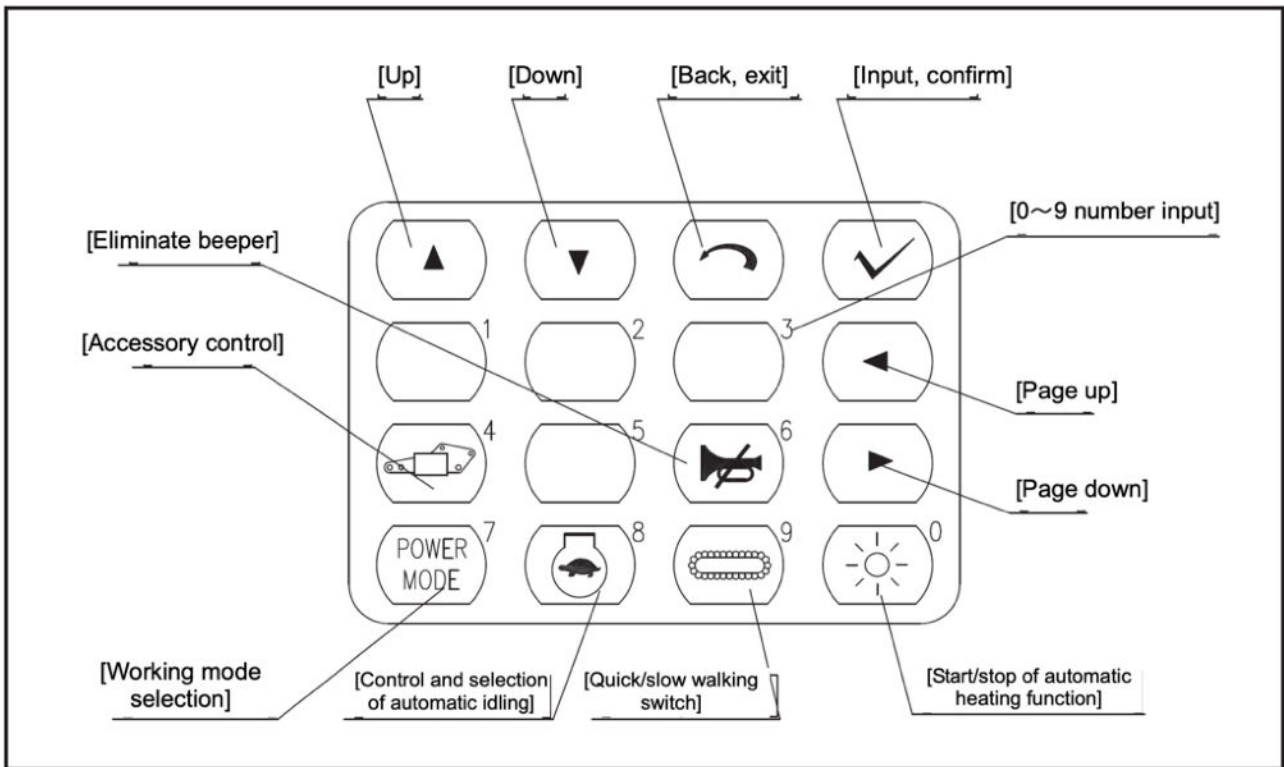

- Note: 1. "Accessory control" is only effective for the specific accessories assembled.
2. "Selection of working mode" is different for the machines of different configuration.

● **Operation of the monitor**

Start the electricity power, the display will start and enter the monitoring interface as shown in the figure. The screen shows the status and information of the machine (before the engine is started, there's alarms about low battery voltage and low oil pressure; when the engine is started normally, the above two alarms will disappear).

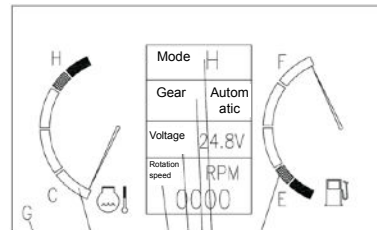





- Fuel level meter (when the fuel level is low, there's alarm in the alarming area of the machine)
- Power modes: mode H, S and L
- Throttle gear: 1~10
- Current voltage of the system, the unit is volt
- Current engine rotation speed , the unit is rpm
- Engine's cooling liquid temperature meter (when the engine cooling liquid temperature is too high, there's alarm in the alarming area of the machine)
- For the machine with GPS, the GPS function is activated.



- **Main screen**

Press the  key to enter “main menu”.

Press the  or  to move the cursor, then press the  key to enter each menu for all kinds of operation.

Press the  key to return to the upper level menu.

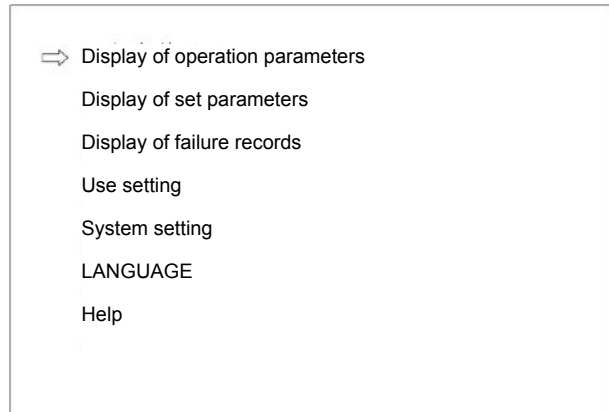

- **Machine working mode**

When the engine is under the normal work status, the power modes can be selected according to the actual working conditions.

**Selection of power mode:** the modes L, S, H and force increase modes are available for this machine. And mode can be selected by pressing the key ?, and the mode can be shown on the screen.

**Mode L:** low load mode

**Mode S:** energy saving work mode

**Mode H:** high drilling force mode

The operator can select the suitable work mode or gear according to the actual work condition and experience.

**Force increase mode:** under automatic Mode S and H, or when the throttle control wheel is above the 8<sup>th</sup> gear under manual mode, “Force increase” operation can be done. The “force increase” order can be sent through the “Force increase” button on the right handle to electrify the electric-magnetic valve, so that the excavator can get the instantaneous force increase. Under the force increase mode, the

mark  will be shown. The interval between two “force increase” actions should not be shorter than 12 seconds.

- **Fuel filling**

1. Fuel must be filled when the engine is stopped (the key is on the "ON" position)
2. Press the "Fuel filling pump start/stop key" for 3 seconds and then release, the fuel filling indicator will be on and the fuel filling pump starts to work. When the fuel level is 95% the fuel filling pump stops working automatically.

If fuel is to be filled to full, then press the "Inching" (fuel filling pump start/stop) button to start the inching fuel filling.

3. Stop of fuel filling: under the working status of the fuel filling pump, press the "Fuel filling pump start/stop button" to stop filling. When the pump is stopped the fuel filling pump indicator is off.

Note: during fuel filling, the operator needs to observe the filling status, and should cut off the electricity power when filling is completed.

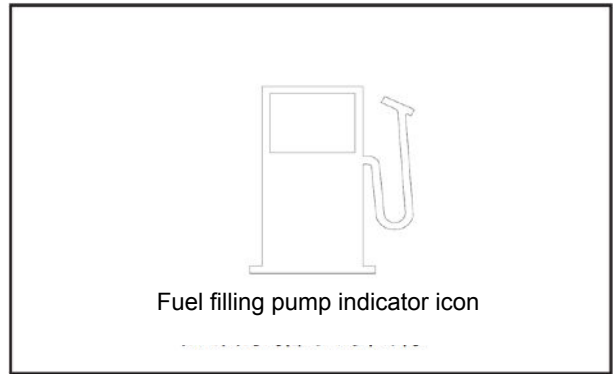

## Left Dashboard

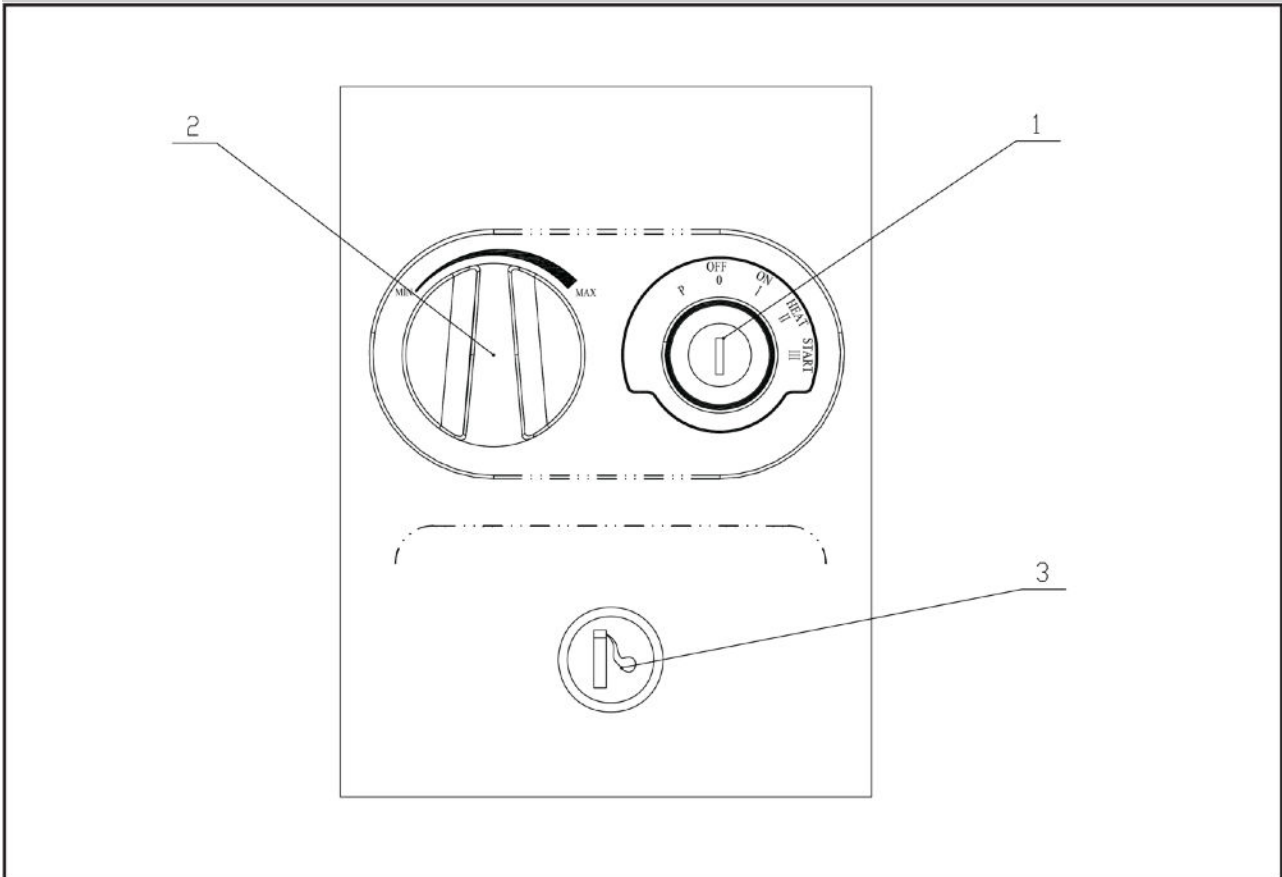

### 1. Start switch

- (o) Stopping position: stop of the electronic system of the machine
- (a) Working position: normal working of the electrical appliances of the machine
- (b) Starting position: when the key is turned clockwise to the starting position, the engine's starter motor starts to work
- (c) Warming-up position: when the key is turned to the warming up position, the engine starts to preheat; at this moment the preheating indicator is on. Pay attention that the preheating time should not exceed 30 seconds. This position can be automatically

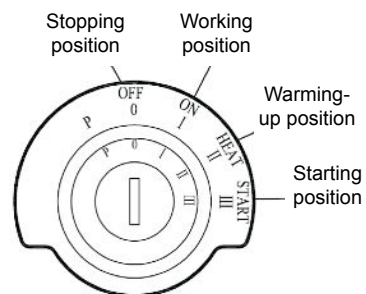

reset.

**2. Throttle knob**

**3. Igniter**

## Command Control Panel (cab left)

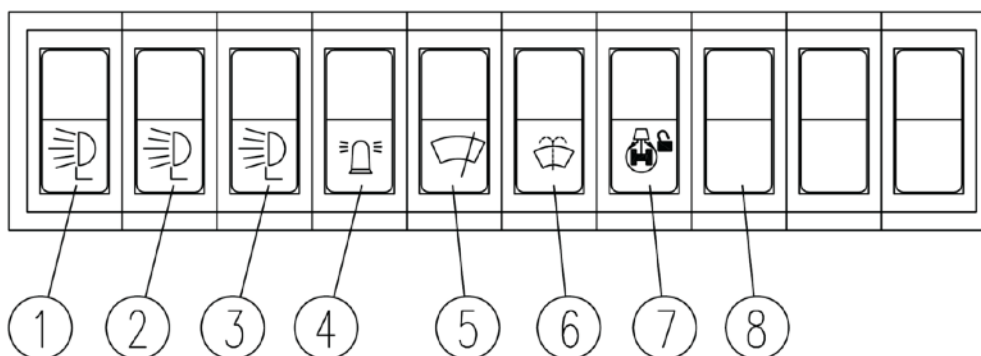

### 1. Boom lamp switch and front working lamp switch

Press the marked part of the button to turn on the lamp, and press the other part to turn it off.

### 2. Cab headlamp switch (OPT)

Press the marked part of the button to turn on the lamp, and pres the other part to turn it off.

### 3. Cab rear lamp switch (OPT)

Press the marked part of the button to turn on the lamp, and pres the other part to turn it off.

### 4. Warning lamp switch (OPT)

Press the marked part of the button to turn on the lamp; And press the other part to turn it off.

### 5. Screen wiper switch

Press the marked part of the button to turn on the lamp; And press the other part to turn it off.

I is the stop gear;

II is the low speed gear;

lii is the high speed gear.

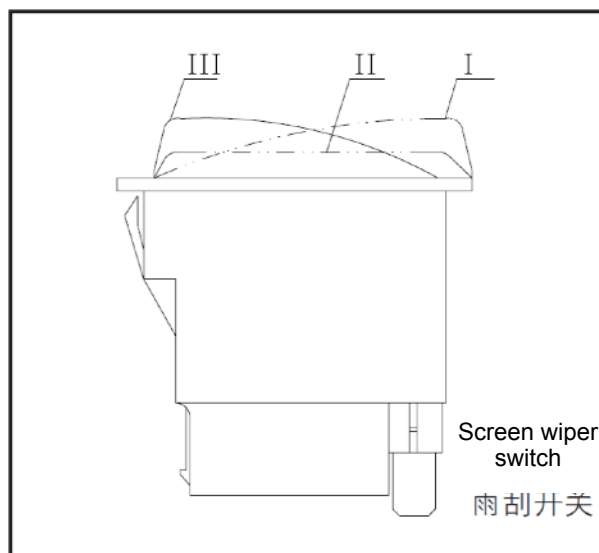

## Safety Locking Parts

### 1. Safety locking handle



**Warning:** Safe locking mechanism of the working device is an important part of security systems. When the driver is leaving the cab, he must do the safe locking. If the left control box is not in the locking position, the stick may move to cause the movement of the work platform or device, resulting in an accident.

#### Pilot lock

When the safety locking handle is pulled up to the top, the pilot system control doesn't supply oil, the machine's working device and platform slew can't work (except the left and right walking operation), thus the machine is protected.

#### Stopping pilot locking

When the safety locking handle is pushed forward to the bottom, the pilot system is connected to the oil pressure source, so the machine can start normal working.

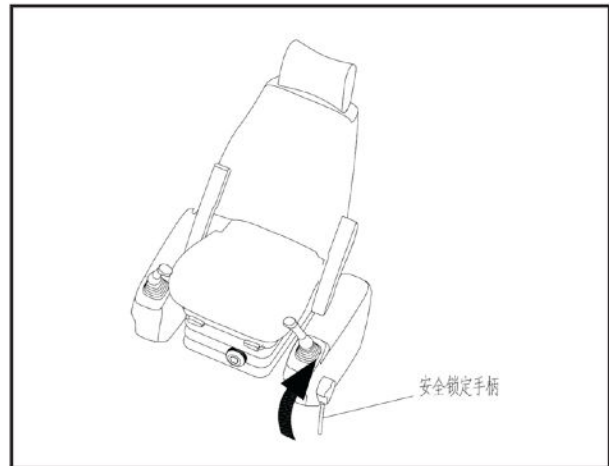

## Manipulation of the Working Device and the Rotary Equipment

### 1. Manipulation of the working device and the rotary equipment of the excavator

#### A. Left pilot handle operation

**Stick control:** when pushed, the stick extends outside, when pulled, it is retracted.

**Platform rotation:** when deflecting to right, the platform turns to right; and when deflects to left, the platform turns to left.

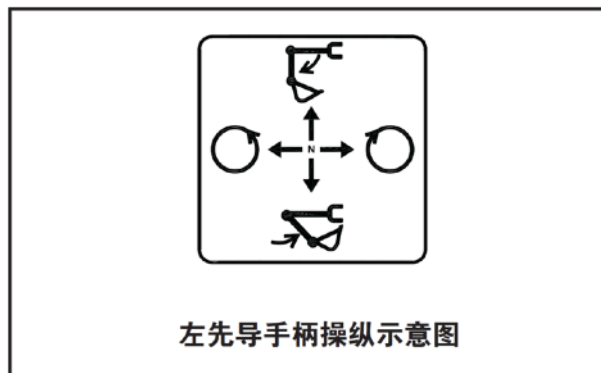

#### B. Right pilot handle operation

**Boom control:** when pushed downward, the boom goes down, and when pulled, it upgrades.

**Bucket control:** when deflecting to right, the bucket turns outside; and when deflects to left, the bucket turns inside.

In order to ensure performance of the machine and safety, the operation pilot handle should be controlled at constant speed as much as possible, and sudden gear shifting is not allowed.

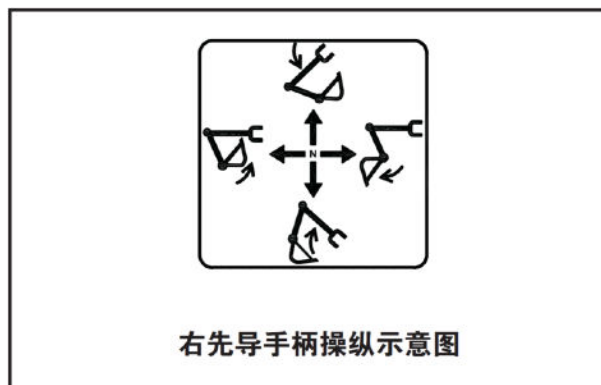

### 2. Operation of assistant working device (OPT)

The assistant working device can be operated through directly stepping the foot pedal.

## Walking Manipulation

### 1. Walking and walking direction manipulation

Manipulate the left and right control rods to control the walking of the track on both sides of the machine.

The unilateral control of control rod enables the machine's unilateral move.

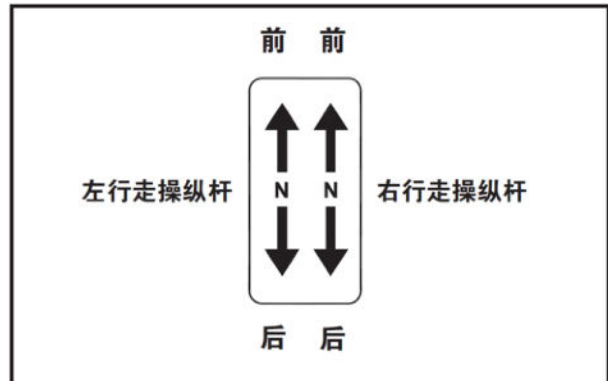

### 2. Speed control

- 1) Walking speed can be switched through the "Driving speed" button on the monitor, and the status is displayed on the meter, see "Monitor" for details.



## Throttle Operation

### A Throttle knob

Turn the throttle knob to the right to increase throttle, and turn left to reduce it. Before the engine is stopped, the throttle knob should be on the MIN position before parking the machine.

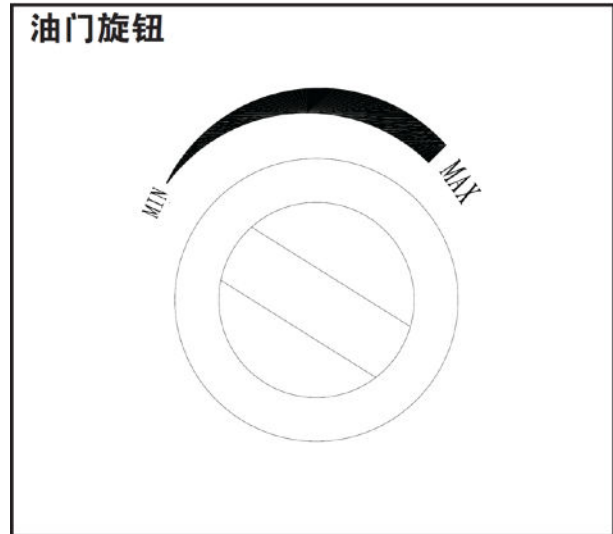

### B. Throttle lever

Pulling backward the engine throttle lever can increase the throttle. Before stopping the engine, push the handle forward to the end, and after stopping the handle is reset.

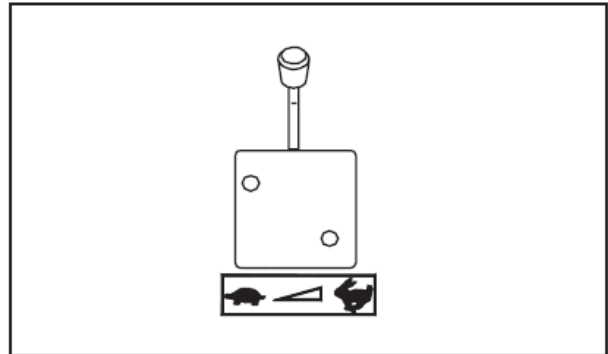

## Driver's Seat



**Warning: Accidental overturn or sudden move of the machine can cause injury and even death. Therefore, for the sake of safety, remember to fasten the seat belts and adjust the seat before starting the machine.**

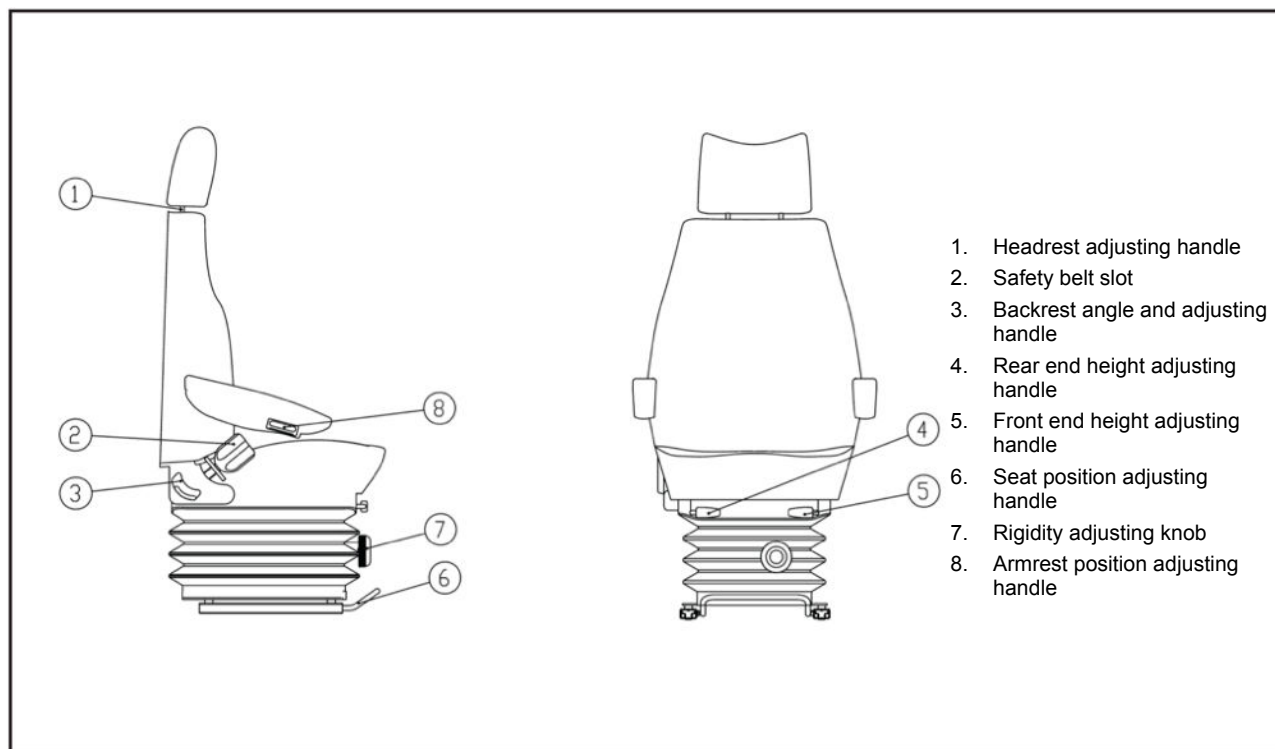

- **Headrest adjustment:** pull the headrest adjusting handle and the headrest to the right position and then release the handle. There are three gears, and each gear is 25mm.
- **Backrest adjustment:** turn the backrest adjusting handle, press the backrest backward to the right position and release the handle. The backrest angle adjusting range is 80 degrees for both front and back.
- **Seat height adjustment:** pull the handle up, and when the seat height is adjusted to a right position by its own weight, release the handle. Height adjusting range is 65mm.
- **Seat position adjustment:** pull the seat position adjustment handle and move the seat to the right position, then release the handle. The adjusting range is 160mm.
- **Seat rigidity adjustment:** turn the rigidity adjusting knob to the comfortable rigidity. The adjusting range is 40kg~130kg.
- **Armrest position adjustment:** turn the armrest adjusting handle to the right height.

**Note: Adjusting must be carried out when the machine is stopping, and after adjusting, jiggle the seat to ensure it reliable locking.**

## Seat Belt



**Warning:** Safety belt is an important part of the safety system of the machine. Before the operation, you must wear the seatbelt. If not, when the machine is overturning, the machine cab or the machine may be down to your body, causing damage.

**Warning:** Before using the seat belt, please check if the belt seat is good enough. If it is damaged or worn, please replace it with a new one.

- Even if there is no damage found in the seat belt, you should also replace it with a new one every three years. The production date of the seat belt is displayed on the label of out-of factory date.
- Be sure to wear the seat belt during the operation.
- When wearing a seat belt, do not make it twisted.

### 1. Fixing the seat belt

Hold the belt clip and check if it is distorted. Adjust the length of the belt, and then insert the tongue firmly in the buckle. Gently pull the seat belt to check if it is properly locked.

### 2. Removing the seat belt

Press the red button on the buckle and remove the tongue from the buckle, then you can remove the seat belts.

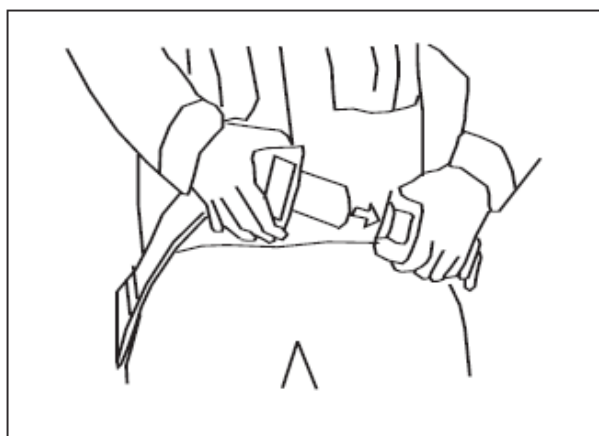

## Air-conditioning Control

Air-conditioning control panel is located on the left control panel switch set.

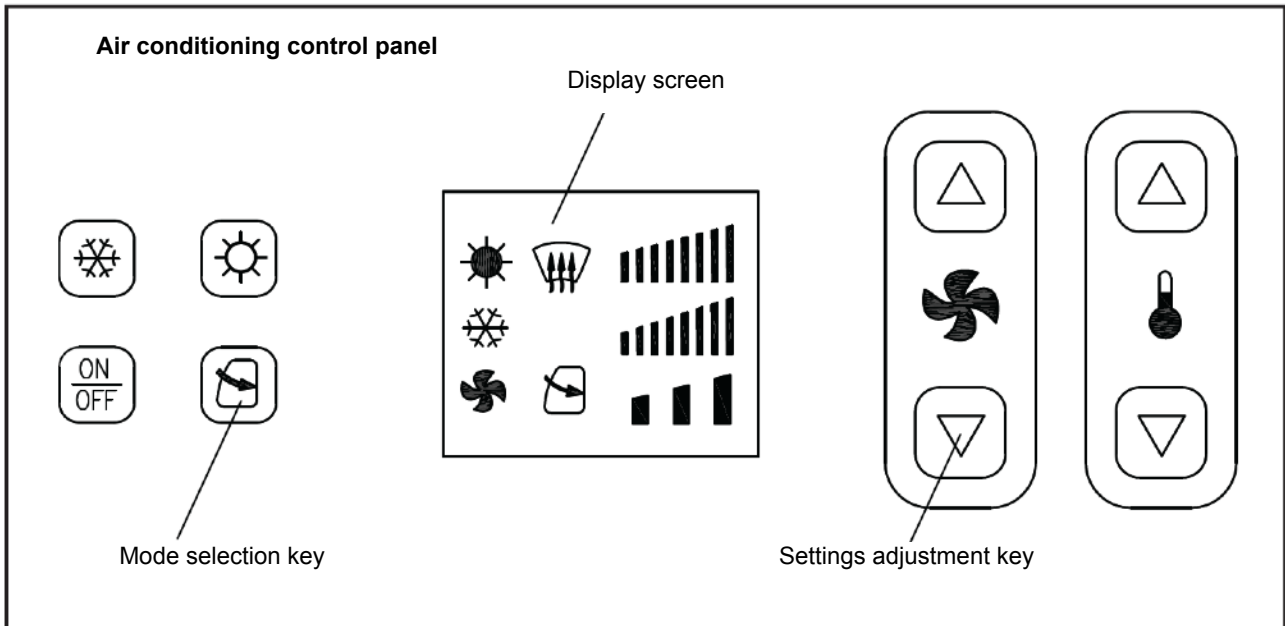

### 1. Key functions and basic manipulation

#### Power Switch



After you press this button, the air-condition system is electric. Open the screen backlight, and have the fan running for 3 seconds (do not accept other operations here). Then restore the state before the last shutdown. When turn on the power, click this button again to remember the current working state (cooling, heating, wind speed, cooling heating capacity setting), and then turn off the power.

#### Cooling key



Press this button in the ventilation mode to remember the current state (wind speed





## Heating key



Press this button in the ventilation mode to remember the current state (wind speed settings), and the system enters the heating mode. The graphics  disappears from the screen (top row), and the system enters the previous ventilation mode.

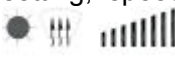

Press this button in the cooling mode to remember the current state (cooling capacity setting, speed setting), and the system enters defrosting mode. The graphics  disappears from the screen, and the system enters the previous ventilation mode (speed setting).

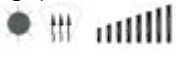
Press this button in the cooling mode to remember the current state (cooling capacity setting, speed setting), and the system enters defrosting mode. The screen displays  (top row, middle row), and the previous defrosting mode (heating capacity settings, speed settings) is stored.

Press this button in the defrosting mode to remember the current state (heating capacity settings, speed settings), cancel the defrosting mode, and the system enters the cooling mode. The graphics  disappears from the screen (top row), and the system enters the previous cooling state (cooling capacity setting, speed setting).

## Circulating air button



 Press this key, and the system enters the outer loop mode. The screen displays . Under this mode, press this button again and the outer loop mode is canceled. The system enters the inner loop mode and the graphics  disappears.



## Key for increasing the setting

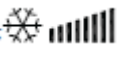
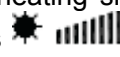

In the cooling mode, pressing this button means to increase the cooling capacity, and the lattice the screen displays  correspondingly increases. In the mode of heating or defrosting (cooling and heating simultaneously), it means to increase the heat capacity, and the screen displays  corresponding increases of the grid. Every time you press the button, a grid is added.

## Key for decreasing the setting





In the cooling mode, pressing this button means to decrease the cooling capacity, and the lattice of the screen displays  (middle row) correspondingly decreases. In the mode of heating or defrosting (cooling and heating simultaneously), it means to decrease the heat capacity, and the lattice of the screen displays  corresponding decrease of the grid. Every time you press the button, a grid is reduced.



Pressing this button means to increase the wind speed, and the screen shows a corresponding increase of grid of . Each time you press the button, a grid is added, and the wind speed increases by 1 file.



Pressing this button means to decrease the wind speed, and the screen shows a corresponding decrease of grid of  . Each time you press the button, a grid is reduced, and the wind speed decreases by 1 file.

## Radio

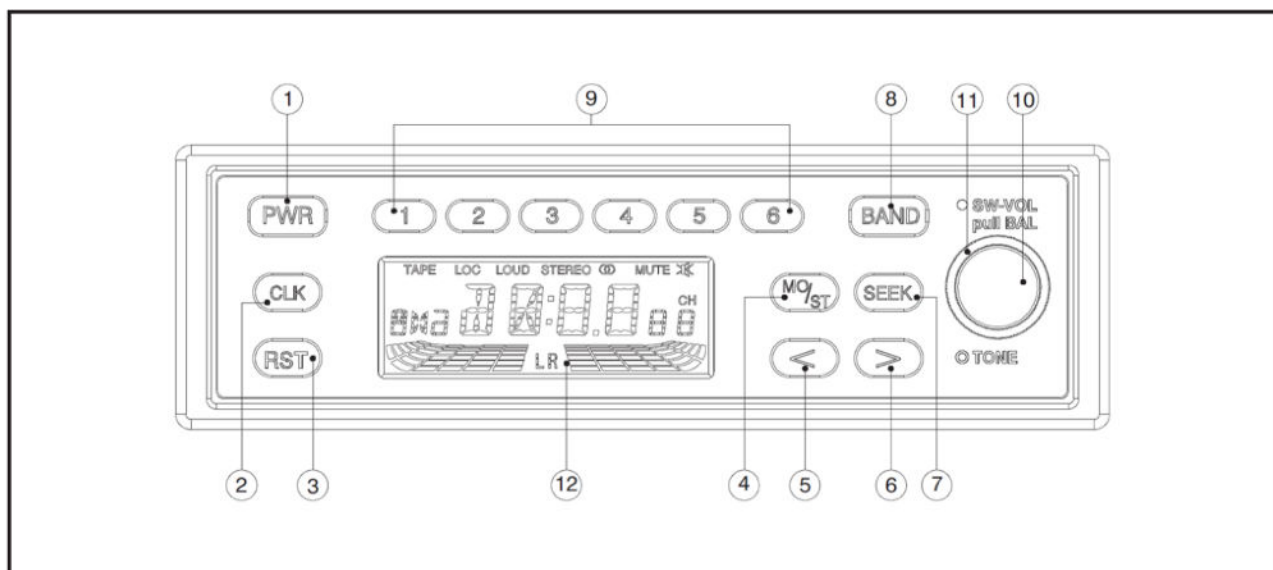

1. Power button
2. Time and frequency shift key
3. Reset button
4. Stereo / mono switch key
5. Manual down to select radio stations / Minute adjustment button
6. Manual up to select radio stations / Hour adjustment button
7. Automatic tuning button
8. Band conversion button
9. Radio preset buttons
10. Volume / balance adjustment button
11. Volume control button
12. Monitor

## Radio Operation Description

### 1. Turning on and turning off

Press the 1 button, the power is turned on and the radio begins working. Press the 1 button again, the power is turned off and the radio stops working. (If the radio is of the automatic power type, pressing any button will turn the radio on, and pressing 1 button to turn it off.)

### 2. Band switching

Press the 8 button, and you will receive the band you prefer, the switch order is FM1-FM2-FM3-AM1-AM2.

### 3. Automatic tuning

Press the button 7 once, the radio will automatically search for the radio stations from low to high, and lock automatically after receiving the radio station, then plays it. If you want to listen to the next station, repeat the previous steps, until you receive the satisfactory radio station.

### 4. Manual turning

When the signal is poor, you can manually select the station, pressing the button 5 and button 6 successively to search for the radio stations up and down. Pressing button 5 or button 6 for a long time, you can quickly search for the radio stations up and down.



## **5. Remembering stations manually**

When you have searched for stations automatically or manually, press (for 3 seconds) the present buttons (1-6 button) for the memory. The response of the button dictates that the current station has been remembered on this button. In the future, as long as you press the present button (1-6 buttons) after turning on the radio, the original radio station can be played.

## **6. Stereo / mono switch**

When receiving the FM station, pressing button 4 MO/ST can make shift between the stereo mode and the mono mode. If it is stereo, the "STEREO" on the monitor lights up. If the symbol "∞" on monitor lights up, it means that the current radio signal is stereo signal. If the stereo radio signal is bad, switch to mono mode to improve the reception quality.

## **7. Time / frequency switching**

When the radio is working, pressing button 2 can make shift of the monitor between the time display and the frequency display. In the time display mode, pressing any button (except PWR key) will make the monitor return to the frequency display mode, and 5s later, it automatically return to the time display mode.

## **8. Time adjustment**

In the time display mode, press button 2 for a long time (more than 3 seconds) and the time starts blinking, indicating that the system enters the time adjustment mode, when you press the button 5 to make adjustment of minute, and press the button 6 to make adjustment of hour. Five minutes after receiving the time adjustment, the system will automatically return to the normal display mode.

## **9. Volume adjustment**

Rotate the inside knob 10, and you will adjust the volume.

## **10. Tone adjustment:**

Rotate the outside knob 11, and you will adjust the tone.

## **11. Left and Right balance adjustment**

Extract out (about 2mm) the inside knob and rotate it, and you will make adjustment of the left and right balance. Please press the button back after adjustment.

## **12. System reset**

If the machine cannot work normally, please press button 3, and it will return to the factory state. If you have further questions, please contact the dealer.

**Note 1: The clock functions of the radio are not used to excavators.**

**Note 2: Due to the different models of the radios, the control panel will be slightly different.**

## Doors and Windows

### 1. Cab door

The door of the excavator is the only path for the driver to go in and out. When the operator leaves the cab, he should lock the door.

### 2. Rear window

Rear window can be used as an emergency exit. When for some reason, the cab door cannot be opened and the trapped driver cannot go out of the cab normally but need to escape from the cab, he can use the escape hammer to hit the rear window until the window is shattered, and then, he can escape.

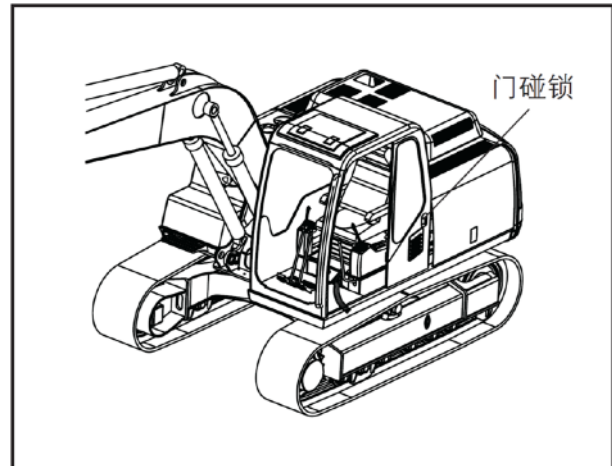

### 3. Front window (flip window)

If the flip window is opened, the driver can get a better viewing conditions and air circulation.

If you want to open the flip window (front window), firstly you need to pull the locks on both sides of the flip window, and then the flip window can slide down and up. When you pull the flip window to the proper position, you can put it to the locking position, and release the handle lock to lock the flip window.

Conversely, you can put the flip window down.

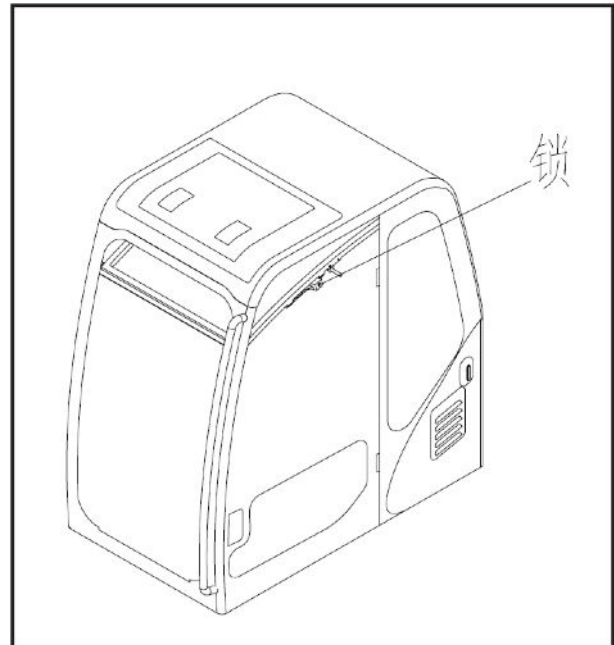

---

**Operating Guide**

## Preparations before Operating this Machine

- 1) The excavator should be operated by the trained driver, who must comply with the specific requirements of the local area before operating independently.
- 2) Unless the drivers have been read carefully the manual, the operation is strictly prohibited.
- 3) Drivers must wear tight-fitting clothing and appropriate adaptation of the safety items such as helmets, shoes, gloves, protective glasses, safety belt light before the operation.
- 4) Every day, before starting, the machine should be carefully checked according to the requirements.
- 5) Check if the working equipments, the tanks and the hoses are damaged.
- 6) Remove the dust and dirty around the engine, radiator and the battery.
- 7) Check if the hydraulic equipment, mailboxes, pipes, joints leak oil. (By the method of inspecting if there are significant traces of oil).
- 8) Check if the frame parts (tracks, driving wheels idles, etc) are broken, if the bolts are loose, and if the connection between the frame and the platform is loose.
- 9) Check the equipment, and the monitoring device should not be damaged.
- 10) Clear and check the mirrors, and adjust the angle to the correct vision.
- 11) Check if the seat belts are broken.
- 12) Make sure that the machine has been maintained according to the requirements.



**Warning: Before the operation, you should make sure that you have understood and remember the contents related to the safe operation of the “safety regulations” in the manual.**

## Engine Operation



**Warning:** Before starting the engine, please refer to the safety details in this operation manual. Read all the safety signs on the machine. There should not be other people in the workplace. Before the operation, you should learn and practice the safe operation firstly. During the operation, you must be clear and follow the partial sections and chapters about the safety operation and maintenance in the instructions, and also should comply with relevant laws and regulations.

### 1. Checking before starting the engine

- 1) Check if the seat belt is fastened, and honk to confirm there is nobody around the workplace and below or above the machine.
- 2) Check the windows, and check if the rear-view mirror can provide good visions.
- 3) Check if there is dust or dirt around the engine, battery, and radiator. If any, please remove it.
- 4) Check if the working device, cylinder, connecting rod and hydraulic hose have split, transition wear or clearance. If abnormal, please replace or repair.
- 5) Check if the hydraulic equipment, hydraulic tank, hoses, and fittings are leaking.
- 6) Check the lower part of the body (track, sprocket, idler, etc.) For damage, wear, loose bolts or leaking.
- 7) Check if the meter display is normal, if the work lights can work normally, and if the electrical wiring has short circuit or open circuit phenomenon.
- 8) Check whether the coolant level, fuel level, hydraulic oil level, and engine oil level are between the upper and lower limits.
- 9) In the cold weather, Check if the coolant, fuel, hydraulic oil, rechargeable batteries, oil and lubricants are frozen. If any, they should be thawed before starting the engine.
- 10) Check if the left control box is in the locking state.
- 11) Check the working condition, direction and location of the machine to provide information for the operation.

## 2. Starting the engine



**Warning:** When there is warning sign of prohibiting starting engine hanging on the manipulation handle, the engine is not allowed to be started.

**Warning:** Before starting the engine, you must confirm that the safety lock lever is in the locked position to prevent the accidental touch with the manipulation control rod in the starting, which will cause a sudden movement of the working device, leading to the accident.

To start the engine in cold weather, it should be pre-heated thoroughly. If the machine is not thoroughly preheated before operating the operation rod, accidents may happen.

**Warning:** If the battery electrolyte is frozen, do not charge it or start the engine with different power supply, which will cause the fire hazard to the battery. Before charging the battery or start the engine with the different power supply, please make the battery electrolyte dissolved. Before starting the engine, please check if the battery electrolyte is frozen or leaks.

Before starting the engine, insert the key to the start switch and turn it to the ON position. Check all of the alarm lights display status on the digital instrument cluster, if any alarms are found, you can only start the engine after the troubleshooting.

### A. Starting the engine under the normal temperature

Turn the key to the start gear to start the engine. (Note: horn for alarming before starting)

When the engine is started, release the key for it to return to the working gear position.

The key should not stay on the starting gear for over 15 seconds. If the machine can't be started with one attempt, start again after around 1 minute.

### B. Starting the engine under low temperature

Turn the key to the preheat gear and stay on the gear, to electrify the preheating grill and preheat the machine. Here the preheating mark  will shine. Then turn the key to the start gear, or release the hand to let the key automatically return to the working gear to stop preheating.

**Note:** preheating time should not be over 30 seconds. Continuous start should not exceed 15 seconds; time interval between two starts should not be shorter than 30 seconds; the engine systems should be checked if the engine can't be started after three attempts.



**Warning:** 1) Never turn the key during the running of the machine, because this will damage the engine.

2) Never start the engine when the excavator is being dragged.

3) Never start the machine by starting the motor in a short circuit.

- **Starting the engine with the auxiliary cable**



**Warning:** When the battery electrolyte is frozen, if you (1) try to charge the battery or (2) make jumper of the engine, the battery will explode. To prevent freezing of the battery electrolyte, please maintain the battery is charged fully. If you do not comply with these instructions, you or someone else will be hurt.



**Warning:** Battery may produce explosive gas. Please be careful to be away from sparks, flames and fireworks. When you the battery is charged or used in a confined area, please pay attention to the continuous ventilation. When working near the battery, you should wear goggles.

If the method of connecting the auxiliary cable is not proper, the explosion may be caused. Therefore, please do in accordance with the following provisions:

- 1) When using the auxiliary cable start, the operation should be carried out by two persons (one is sitting in the seat, and the other is operating the battery).
- 2) When starting with another machine, do not allow two machines contact.
- 3) When connecting the auxiliary cable, you should turn the keys of the faulty machine and the normal machine to the "OFF" position. Otherwise, when switched on, the machine may move to cause danger.
- 4) When connecting auxiliary cable, be sure to finally connect the negative (-) pole of the battery; When removing auxiliary cables, you should first disconnect negative (-).pole of the battery.
- 5) When removing the auxiliary cables, the auxiliary cable clamps should not touch with each other, and should not touch with the machine too.
- 6) When starting the engine with the auxiliary cables, be sure to wear goggles and rubber gloves.
- 7) When connecting the faulty machine and the normal machine with the auxiliary cables, you should use the normal machine whose battery voltage is the same with the faulty machine.

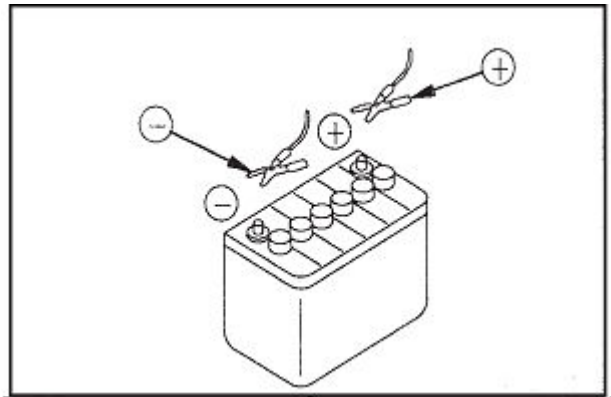
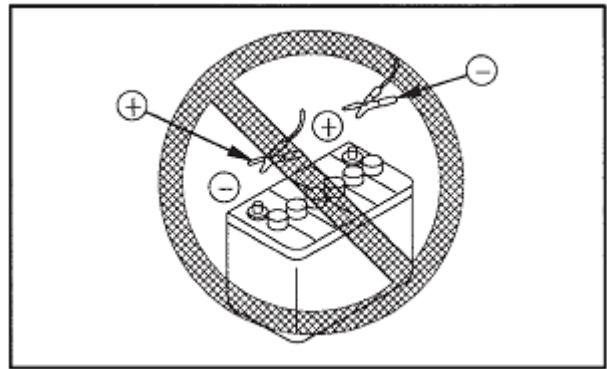







### 3. After starting the engine

#### A. Warm-up of the engine and the machine

The normal operating temperature of hydraulic oil is 50 °C -80 °C. The hydraulic oil whose temperature is below 20 °C will damage the hydraulic components in the operation. Therefore, before starting work, if the oil temperature is below 20 °C, it must be warmed up according to the following heating process

Select or cancel the heating mode through pressing the  key.

When the automatic heating mode is selected,  or  will be shown in the information area of the screen. The engine will run at idle speed when it's started. When the engine's cooling liquid temperature is below 40°C, the engine can only run at below the 3<sup>rd</sup> gear and the machine can't work. When the engine's cooling liquid temperature is above 40°C, the heating process stops, and the engine can be shifted to above the 3<sup>rd</sup> gear for working (automatic mode or manual mode).

When the automatic heating mode is cancelled,  or  will not be shown.

#### B. Checking after starting the engine

- 1) Check if all the alarm indicators go off.
- 2) Check if there is oil leakage (lubricate oil, fuel) or water leakage.
- 3) Check if the sound, vibration, smell and instrument of the machine are normal. If there is any exceptions, please handle it immediately.

### 4. Turning off the engine

**Note: If the engine is suddenly turned off before cooling off, this will greatly shorten the life of the engine. Therefore, except in emergencies do not suddenly turn off the engine.**

**If the engine is overheating, do not suddenly turn off even more. You should make the engine run in the middle speed to be gradually cool, and then turn off it**

- 1) Turn the throttle knob or handle to the Min. Speed position.
- 2) Run the engine in an idle for about 5min to make it gradually cooled.
- 3) Turn the key switch to the "OFF" position, and turn off the engine, with all the indicators off.
- 4) Remove the key of the starter switch.

### 5. Checking after turning off the engine

- 1) Inspect the working device, outside the machine and the chassis, and check if there is oil leakage or water leakage. If there is anything abnormal, please make treatment immediately.
- 2) Refueling to the fuel tank
- 3) Check if there are scraps of paper or debris in the engine room. If any, clear them to prevent fire.
- 4) Remove mud attached to the chassis.

## Getting in or out of the Machine

- 1) Make sure to clench the arm of the cab as shown in the picture (shown by the arrow in the picture)
- 2) Make sure your feet step steadily on the track.
- 3) When getting on or off the machine, you should not take the control rod as handrails to grasp.
- 4) When getting on or off the machine, you must confirm that there is no mud, grease and other slippery substances on the surface of the track and the handrail. If there is any such substance, please clean it up.
- 5) Do not jump on or jump off the machine. Do not get on or off the machine when it is running.

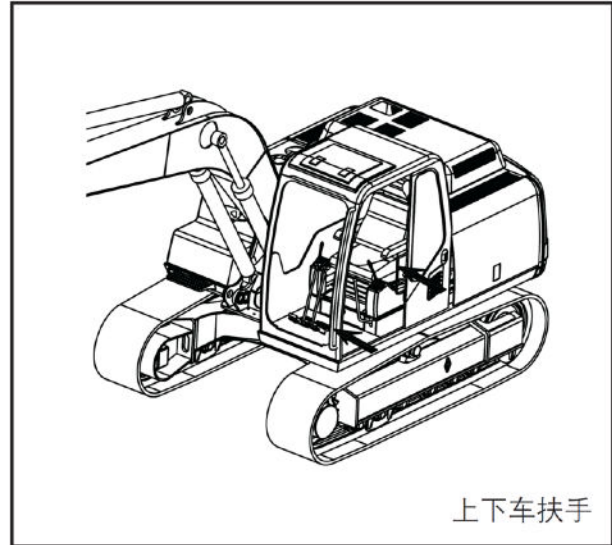

- 6) Before leaving the machine, the working device should be lowered to the ground, then pull the safety locking handle to the top to turn off the engine, and keep the machine on this status until the next machine operation.

**Note: when leaving, please take the keys and have all the doors and windows locked.**

Climbing onto the hood and cab roof is forbidden.

No matter under what state, nobody is allowed to be on the working device (such as bucket, stick, boom and accessories)



## Moving of the Machine

### 1. Safety principle of moving the machine

- 1) Before starting the excavator, you should be familiar with the surrounding environment, the availability of pedestrians and obstacles, and the ground bearing capacity and so on.
- 2) When starting the machine, please honk to warn others.
- 3) The drivers are strictly prohibited to start or manipulate the machine on the ground.
- 4) Walking and operation of the excavator must be on the road 1.5 times width than that of its own.
- 5) When walking though the underground passage, the bridges, or power lines, you should have the gesture command.
- 6) When walking, you must lower the boom, stick to maintain the best gravity position.
- 7) When walking, nobody but the driver is allowed to be on the machine.
- 8) When working on level road for a long distance, the platform is unlocked. But the platform must be locked on uphill and downhill.
- 9) Before operating steering handle, you should check the direction of the track frame.
- 10) If the blade is at the back, the manipulation of the control rod is to the contrary
- 11) Do not let anyone in the area around the machine.
- 12) Clear all the obstacles on the walking line of the machine.
- 13) The rear of the machine is a blind spot, so when reversing, please pay special attention.

**Warning: The sudden convert of control rod in the high-speed walking is dangerous.**



- 1) **Do not suddenly transform the control rod; otherwise it will cause a sudden movement.**
- 2) **Avoid a sudden switch to the control rod from the forward to backward (or from backward to the forward).**
- 3) **Avoid sudden conversion of the control rod, such as a sudden stop from high speed (release the lever)**

### 2. Equipment of moving the machine

Pull the throttle knob or handle to the high-speed position to increase the speed of the engine.

### 3. Moving the machine forward

- 1) Adjust the control box to the free position, and raise the working device 40-50cm off the ground.
- 2) Manipulate the left and right walking control rods

When the march sign is on the front part of the machine:

Slowly push forward the front of the control sticks to make the machine walk.

When the march sign is on the rear part of the machine:

Slowly pull back the control rods to make the machine walk.

**Note 1: At low temperatures, if the walking speed is not normal, the machine should be warmed up thoroughly. If the abnormal speed is due to the soil plug of the lower body, please remove the dirt and soil on the lower body.**

2. When the machine is walking at high speed and turning, the platform will swing slightly due to inertia and it's a normal phenomenon.

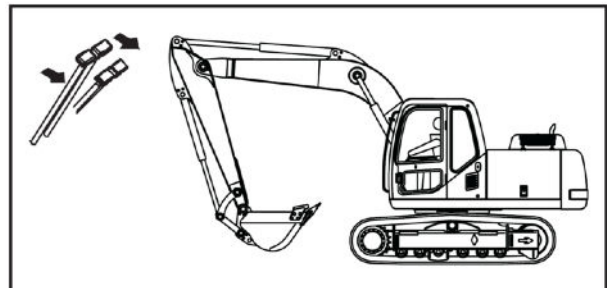
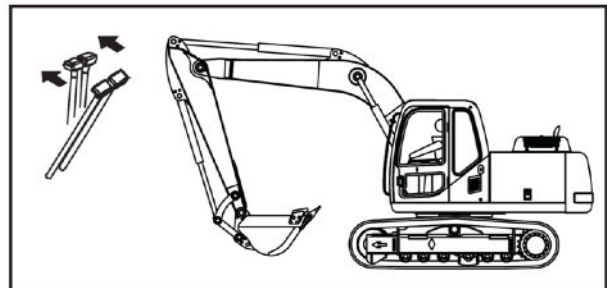
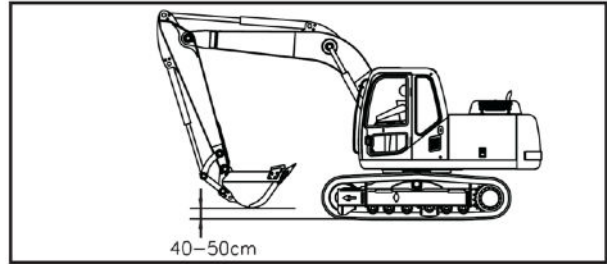

### 4. Moving the machine backward

- 1) Push the safety locking handle forward to the end, to lift the working device up to 40 to 50cm above the ground.

### 5. Stopping the machine

Put the left and right control rods in place, and you will stop the machine.

**Note: Do not stop the machine suddenly during its walking. The parking space should be enough.**

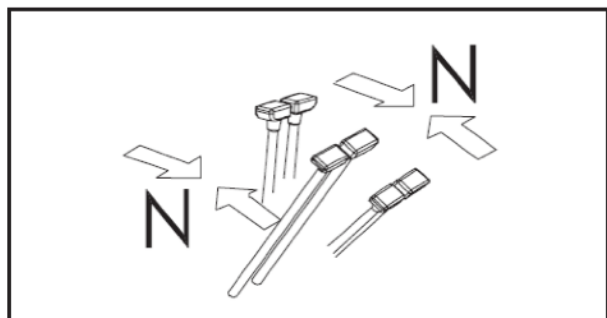

## Turning the Machine

**Note: Before manipulating the control rod, you should check the position of the March sign. If it is at the back, then the operation of the control rod is to the opposite.**

Change the direction of the walking with the left and right control rods.

Avoid the sudden change as possible as you can. Especially when doing the reverse movement (in situ steering), you should stop the machine before make the turning.

## 1. Turning when the machine is stopped

When turning left (see the right side figure):

When the machine is walking forward, push forward the right control rod and the machine will turn left. When the machine is walking backward, pull back the right control rod, and the machine will turn left.

When turning right, please manipulate the left walking control rod in the same way.

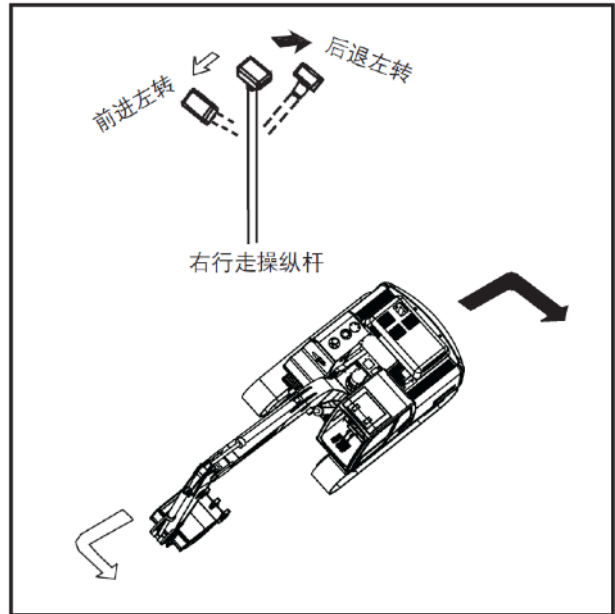

### Turning in situ

When turning left in situ, pull the left control rod backward and push forward the right travelling control rod.

When turning right in situ, pull the right control rod backward and push forward the left travelling control rod.

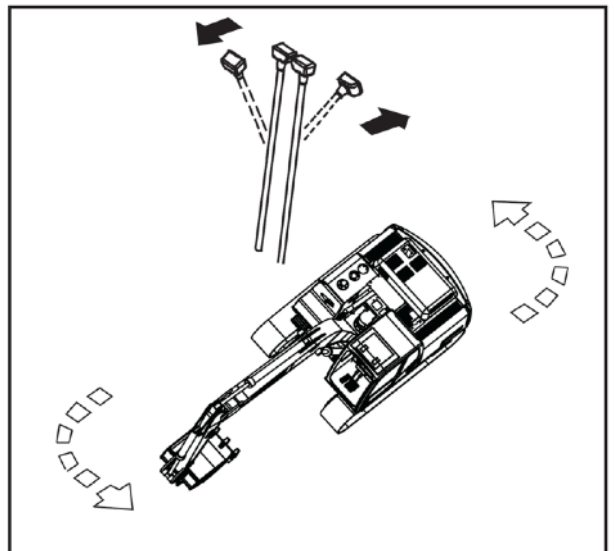

## Rotation of the Machine

- Before rotating the upper part of the machine, please check if the surrounding area is safe enough.
- If you operate the rotation control rod quickly, the upper structure will rotate quickly. If you operate the rotation control rod slowly, the upper structure will rotate slowly. Please have a good control of the speed of operating the control rod.

1) Before starting slewing, press the marked side of the slew switch to stop platform slewing.

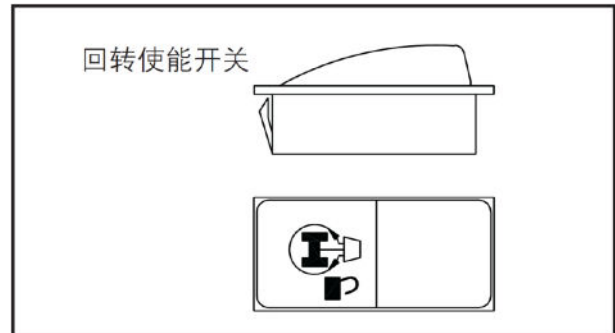

2) Manipulate the left working device control stick to make the rotation operation.

3) Before starting slewing, press the unmarked side of the slew switch to lock platform.





## Selection of Machine Work Mode

The correction selection of work mode is good for the machine to exert its working ability under different work conditions.

Switch between automatic and manual mode can be done through selection of mode on the screen.

		Work mode	
Manual (HAND )		Automatic (AUTO)	
Engine rotation speed can be selected through the throttle knob that has 1-10 gears.	This work mode can satisfy the requirement of the operator in selecting the appropriate rotation speed according to the work condition and his experience	H	Heavy work mode, to satisfy the max. Requirement for productivity.
		S	Standard work mode, focusing on the requirement for productivity.
		L	Light work mode, focusing on the requirement for precise control.
Automatic idle mode	When the work has stopped for 5 seconds, engine speed will enter standard idle condition, and if it's stopped for 200 seconds, engine speed will reduce to the min. When operation is re-started the machine will return to the work mode before idling. But if the automatic idle mode is eliminated, the above functions are not present. However the automatic work mode is not suitable under such conditions as the machine is moving to the transportation vehicle, when the automatic mode ○ is cancelled considering safety.		
Force increasing mode	During work process, sometimes drilling force should be increased through the touch-type force increasing button on the left pilot operation handle. The drilling force can be increased by 10% in 8 seconds. This force increasing mode can only be done under modes H and S, or when the rotation speed is above the 6 <sup>th</sup> gear. For your machine's life please do not use this mode as the normal drilling mode.		
Safety mode	When the engine is started, no matter the position of the throttle knob, engine rotation speed is maintained at the min. Speed. Engine speed can only be adjusted after the throttle knob is turned, or the control mode is changed. This mode can't be cancelled.		
Mode B	Turn the selection knob to Mode B, for using the crushing hammer. Here no matter the position of the throttle knob, the engine speed is constant at 1800rpm, and the hydraulic pump can provide a crushing flow of 200L/min.		

## Working Device Operation

If you operate the working device control rod quickly, the working device will rotate quickly. If you operate the working device control rod slowly, the working device will rotate slowly.

Working device is operated by the pilot valve. The left control pilot valve controls the stick and rotation (if fitted with the steering head, the left pilot valve also can operate the swinging of the steering head). The right control pilot valve controls the boom and bucket.

When you release the control rod, they will automatically return to the neutral position, and the working device maintains in place.

If you operate the control pilot valve within 15 seconds after turning off the machine, you can also put the working device down to the ground.

In addition, you can operate the control pilot valve to release the remaining pressure within the hydraulic oil circuit as well as make the boom fall down after the machine is on the trailer.

### 1. Stick control

Manipulate the left control pilot valve, and if it is pushed forward, the stick will extend out, while if it is pulled back, the stick will retract inside.



### 2. Rotation control

Manipulate the left control pilot valve, and if it is turned left, the platform will turn left.

### 3. Boom control

Manipulate the right control pilot valve, and if it is pushed forward, the boom will fall down, while if it is pulled backward, the boom will rise.

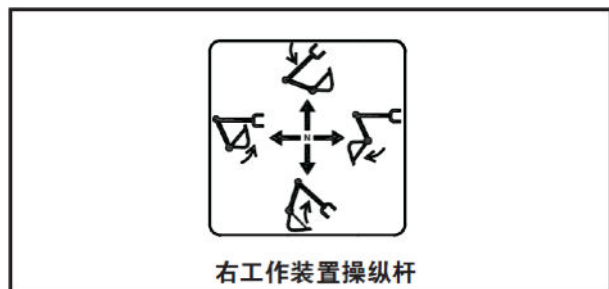

#### **4. Bucket control**

Manipulate the right control pilot valve. The bucket turns outside when it turns right, the bucket turns inside when it turns left.

**Note: the pause phenomenon may occur in the stick operation, which is not a mechanical failure but a normal phenomenon of the excavator. Because when the stick is in operation, the machine's own weight increases the speed of the stick move, resulting in the oil starvation.**

## Working on Slopes or in Water



**Warning:** Construction near the foothills slope is very dangerous. The different working conditions such as rain, muddy ground, snow on the ground, frozen ground, loose sand and soft ground brings potential danger to the safe operation. Therefore, when constructing in the dangerous sites such as in the foothills or on the slope, you should determine whether the operation is safe for the decision-making.

- When walking, the bucket will rise from the ground about 20-30cm.
- Do not walk backwards downhill.
- When the machine is walking on the bulge thing or other obstructions make the working device close to the ground and walk slowly.
- Do not turn on slopes or cross the slope. You can go to the flat place to make turn in advance.
- When working on the slope, turning or operating the working device will make the machine off balance and overturn, so please avoid such operations. When the bucket is with load, rotation toward the downhill direction is very dangerous.
- If such operation must be carried out, you should pile up a platform with soil to keep the balance of the machine in the operation.
- Do not walk up or walk down on the steep slopes, because such operation will cause danger of overturn to the machine.
- When walking uphill, if the tracks slip or the force of the tracks is not enough to walk uphill, do not use the force of the stick to help the machine walk uphill, because such operation will cause danger of overturn to the machine.
- When walking uphill, ensure the engine and hydraulic oil have been warmed up properly, otherwise an accident may be caused.

### Allowable water depth

Do not drive the machine in the water whose depth exceeds the centerline of the under roller.

Increase butter to the parts soaked in water for a long time, until the used butter has been completely squeezed out.

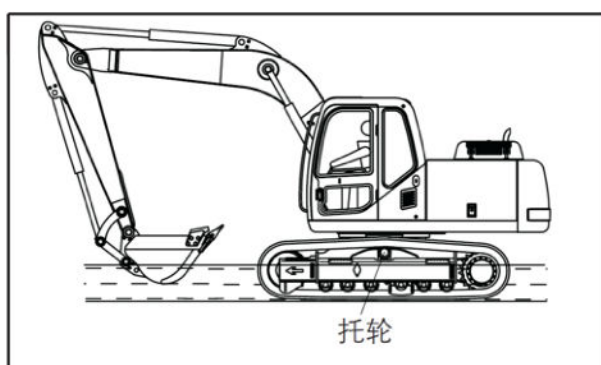

## Out of the Muddy Environment

Please always operate carefully to avoid falling into the mud. If the machine falls into the mud, you should drive the machine out of the muddy environment according to the following steps:

### A. Track of one side into the mud

**Note: When lifting the machine with boom or stick, be sure to make the bottom of the bucket contact with the ground. (Do not use the bucket teeth to push). The angle between the boom and the stick should be  $90^{\circ}$  to  $110^{\circ}$ .**

When only one side track fall into the mud, lift the track with the bucket, mat boards or logs and drive the machine out.

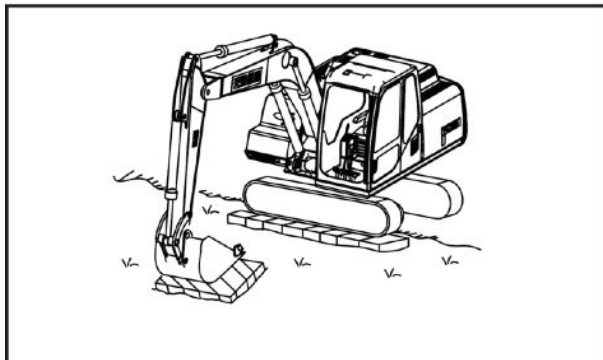

### B. Tracks of both sides into the mud

If tracks of both sides are caught in the mud, and they cannot be moved due to the skidding, mat boards or logs according to the method provided above. Insert the bucket into the front ground, manipulate the stick in the same manner with digging, and adjust the walking control stick to the forward position to pull out the machine.

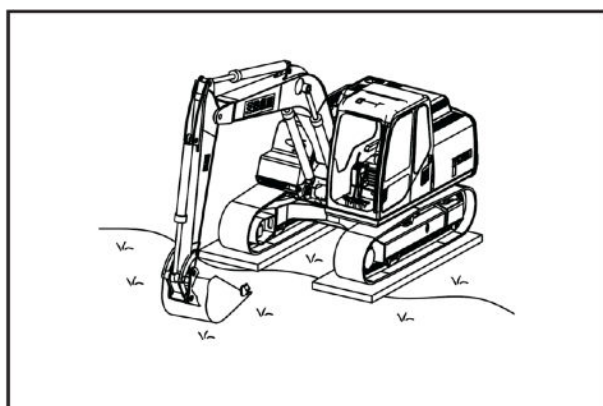

# Construction Operations Guide

## 1. Backhoe operation

Backhoe is suitable for the excavation in the position lower than the machine.

When the machine is in the state shown in the right picture, that is, when the angles between the bucket cylinder and linkage, the stick and the stick cylinder are both  $90^\circ$ , the push force of the bucket is biggest.

The effective use this angle in the excavation can optimize the efficiency.

The excavation scope of the stick is between  $45^\circ$  leaving the machine and  $30^\circ$  toward the machine.

The scope may be different due to the different depth of excavation, but please carry out the operation in the above range as possible as you can, and do not operate the cylinder to the end of its trip.

**Note: As to the hard rock surface, you'd better carry out the excavation after the surface has been broken in other ways, which not only reduces the damage to the machine, but also is more economical.**

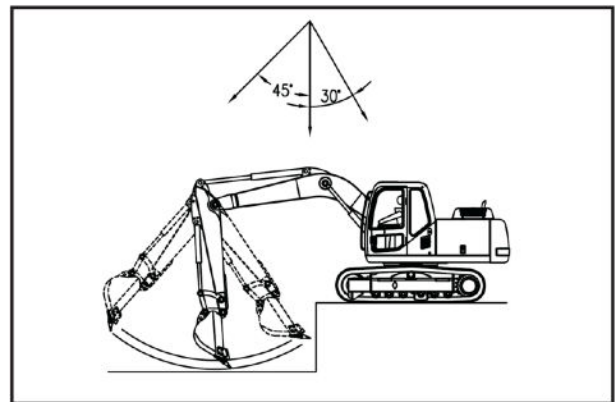
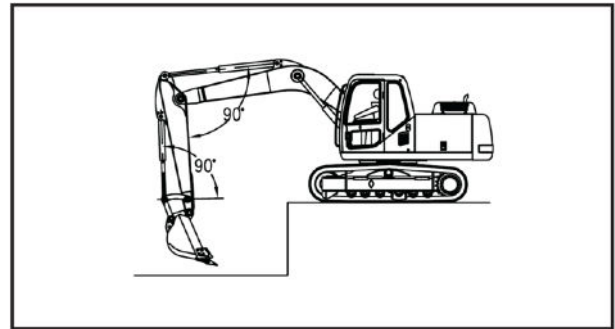

## 2. Loading operation

In the place where the rotation angle is smaller, making the dump truck stop where the operator can easily see will make the operation more efficient.

Compared with from one side of the dump truck, loading from the rear of the dump truck is more convenient, and the loading capacity is greater.

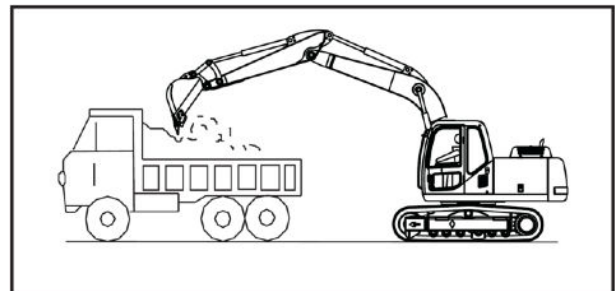

### **3. Trenching operations**

Extend the boom and stick, and make the bucket teeth inserted into the soil.

In the process of stick cylinder excavation, you should timely adjust the cut angle and the loading angle of the bucket, or carry out the digging with the bucket cylinder. Do not insert the bucket teeth into the soil too much to avoid the machine fail to dig the soil due to the overloading of the hydraulic system. In case of the failing of ground-breaking, you can lift the boom appropriately, and the situation will change. After the bucket is full, raise the boom and stick to make the bucket above the ground, and then turn the platform to the proper location for dumping.

#### **Note:**

- 1) Never touch the wires in the air.**
- 2) Before digging, know clearly the situation of the underground pipes and cables, to avoid breaking the pipes or the electric shock accident.**
- 3) When there is an electric shock accident, the driver does not leave the seat, and warn others not to approach.**

### **4. Shaking off the sand and soil in the bucket**

Make the stick in the state of approximate level, and the bucket in the state of unloading. If the sand and soil remain there, manipulate the bucket control stick left and right for a few times, then the sand will come out from the bucket. Never use the impact vibration of the end trip of the bucket cylinder to shake the sand.

### **5. Precautions for the use of the related components**

#### **A. Precaution for the use of tracks**

- 1) Too much debris into the tracks will increase the operating strength of the tracks, resulting in the damage.
- 2) Avoid the sudden turn on the road with strong friction.
- 3) Try to avoid the tracks stained with salt water or salt air, because the salt will corrode the track.
- 4) If the track is not under use for a relatively long time, it should be saved in a cool and dry place.
- 5) When one track and the front device are being jacked up, you can not drive the machine with the other track, because such operation will cause wear and tear.
- 6) When walking, the track cannot be relaxed; otherwise, the track may fall off or subject to the damage.

## Disassembly and Installation of the Bucket

### Safety principles

- When you are striking the pin bearing, the metal debris may fly into your eyes, causing serious injury. So when doing this, you should always wear goggles, helmets, gloves and other protective equipment.
- When removing the bucket, you must put the bucket steadily.
- If the pins are hit hard, the pin can come out and hurt the people within the surrounding area. So, before hitting the pins, make sure that the surrounding area is safe.
- When removing the pins, do not stand below the bucket, and do not let the feet or any part of your body below the bucket.
- When removing or installing the pins, please do not have your hand bruised.
- When facing the hole, do not put your fingers into the pin.

### Installation

Put the machine on a solid and flat face. In the working of connection, for the sake of the safety, you should understand the signal of each other.

Have the excavator in the working state, facing the bucket, and manipulate the stick, until the holes of the stick and bucket in the same line, and then insert a steel bar ① of  $\phi 30\text{mm}$  into the hole.

Lift the boom and stick to make the bucket hang on the stick vertically.

Manipulate the stick cylinder, to make the hole of the connecting rod and the holes of the bucket are on the same line. Install Shaft ②. Remove the steel bar ① and install Shaft ③.

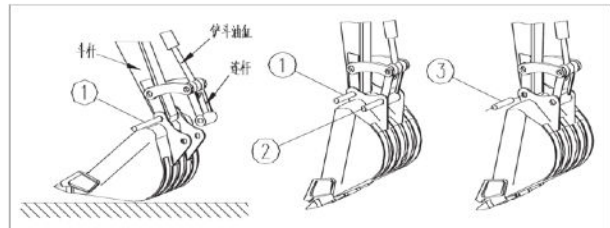

### Disassembly

Stop the machine on a solid, flat surface, with the bucket on the position of just contact with the ground. If the bucket heavily falls to the ground, the resistance will be increased, and the pin will not be removed easily.

Remove the bolts and dual-nut bolts of the locking bolts on the stick and the connection rod. And remove the stick pin ③ and the connecting rod pin ②, and then remove the bucket.



## Parking the Machine

### Safety principles

- 1) Avoid a sudden stop. When you are parking the machine, please leave a space as large as possible.
- 2) Park the machine on the solid and flat ground and avoid parking the machine on slopes. If the machine must be parked on the slopes, put the pads under the tracks and insert the working device into the ground to prevent the moving of the machine (See the right figure).
- 3) If you hit the working device control stick accidentally, the working device will move suddenly, resulting in serious personal injury or accident. So, before you stand up from the seat, you must make the safety lock lever fixed in the locking position.

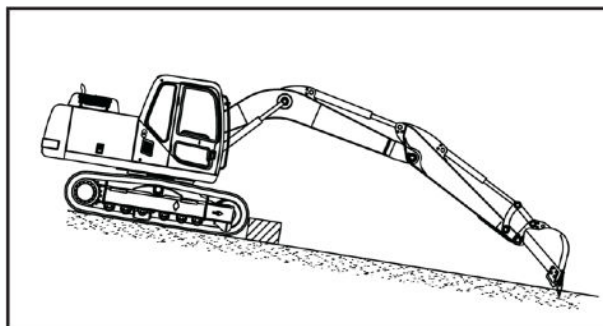

### Parking the machine

- 1) Stop the machine with the left and right walking control stick in the neutral place.
- 2) Do not immediately stop the machine after the heavy-duty work. Let it run for 5 minutes at a low speed to clear the overheating, and then shut down the machine.
- 3) Put the bucket and the bulldozing plate down to the ground.
- 4) Push forward the throttle to the end.
- 5) Turn the starter key to the "OFF" position (all the indicators go off).
- 6) Press the unmarked side of the slewing switch to lock the platform.
- 7) Pull the safety locking handle up to the end to lock the pilot function.

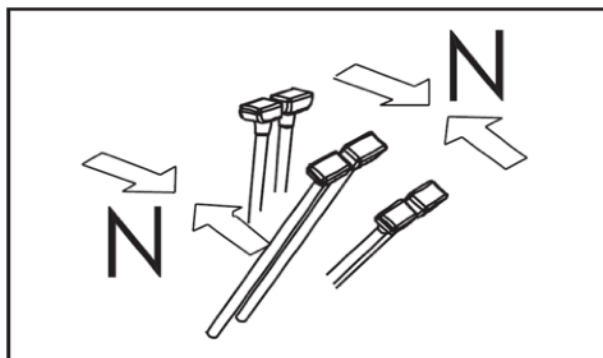

## After Operation

### 1. Inspection

Check the engine temperature, oil pressure, fuel pressure, fuel level, etc. On the digital monitor of the machine.

### 2. Locking

Please lock the following places:

- 1) Cab door (do not forget to shut the windows and the flip window). In any case, if you want to open the flip window, you need to first pull the handle lock on the both sides of the flip window. By operating the handle of the flip window handle locks, you can make the flip window slide upward and downward. When the flip window is pulled to the proper position, push upward the flip window to the locking position, release the handle lock and lock the flip window. Conversely, you can operate the flop window down.
- 2) Oiling port of the fuel tank
- 3) Oiling port of the hydraulic tank
- 4) Battery cover
- 5) Engine cover

**Note: When you open the engine bonnet, there should be nobody standing behind it to avoid the harm to the human body by the sudden hop of the engine bonnet.**

## Handling and Transport of the Machine

### 1. Safety rules of the machine shipment

- 1) Run the machine at a slow speed, and operate slowly the machine when loading or unloading.
- 2) During the automatic warm-up operation, do not handle the machine.
- 3) If the automatic warm-up operation is canceled in the process of the handling operation, then the speed will suddenly change.
- 4) When handling the machine, you should choose a solid and flat surface, with a safe distance to the edge of the road.
- 5) Please use the ramp with sufficient width, length, thickness and strength, with the board's width equal to 1.2-1.5 times the width of the track. To avoid any failures, the handling gradient is proposed to be less than 15°, or the length of the slope is more than 3.5 times the height. When the soil pile is to be used, please compact the pile completely, and take measures to prevent the collapse of the slope.
- 6) To prevent the machine from slipping on the ramp, you should remove all the soil and dirt on the track before starting. Please make sure that the ramp surface is clean, without water, snow, ice, grease or oil.
- 7) Do not correct the direction on the ramp; otherwise the machine will have the risk of overturn. If you have to, please drive the machine out of the slope and correct the direction, then enter the ramp again.
- 8) Do not use the working device for the handling operation, for it is very dangerous.
- 9) When you are on the ramp, do not any control stick but the walking control stick.
- 10) At the direct junction point of the ramp and the transport truck, the machine's gravity center will suddenly change, resulting in a dangerous of losing balance. Therefore, please walk slowly when crossing this position.
- 11) The transport vehicle is unstable when you turn the upper part of the machine. Therefore, you should pull back the working device and turn the machine slowly.
- 12) No matter when getting on or getting off the truck, you should wedge the wheels of the transport truck.
- 13) During the transportation, maintain the machine a fixed position on the transport vehicle with a big wedge and tie the excavator to the transport vehicle with ropes.
- 14) Upon completion of the work or the end of the manipulation, the driver should first lift the safety locking handle to cut off the oil source of the pilot valve before he leaves the seat, to avoid the malfunctions of the machine by the touch of the stick by mistake or unintentionally.
- 15) Before going uphill and downhill, platform locking pin should be put down, preventing platform rotation.

## 2. Loading

- 1) Loading can only be carried out on the solid and flat ground, with a safe distance to the road edge.
- 2) Impose appropriate brake to the transport vehicle, and put pads under the tires to ensure that the transport vehicle cannot move.
- 3) Install a ramp between the truck and the machine, and ensure that the ramps of both sides at the same horizontal surface. The gradient of the ramps should not exceed 15 degrees. Adjust the distance of the ramps to match the track enter.
- 4) Lock the slewing platform.
- 5) Align the excavator and the slab ramp, with the blade at the rear. For the sake of the safety, you should make the excavator near the ramp, and climb slowly to the end of the slope.

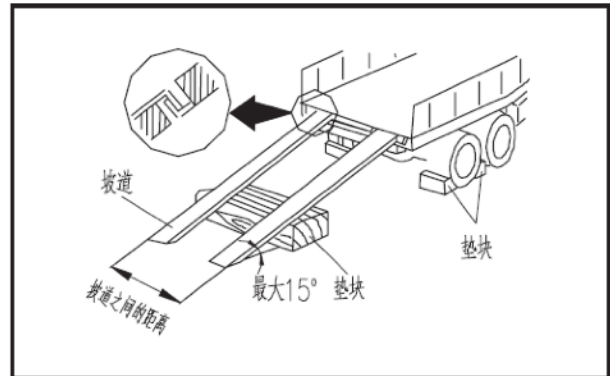

**Note: When on the ramp, you can only operate control rod, and do not operate other sticks or pedals.**

- 6) Stop driving and overhang the stick (position B in the picture), making the front of the excavator track fall to the floor of the transport truck. During the down-dip of the machine, do not let the working device touch the body of the truck. Drive the machine continually to the required position on the transport vehicle.
- 7) Put down the stick, make the bucket fall to the floor, put down the blade and stop the machine at the required location on the transport vehicle.

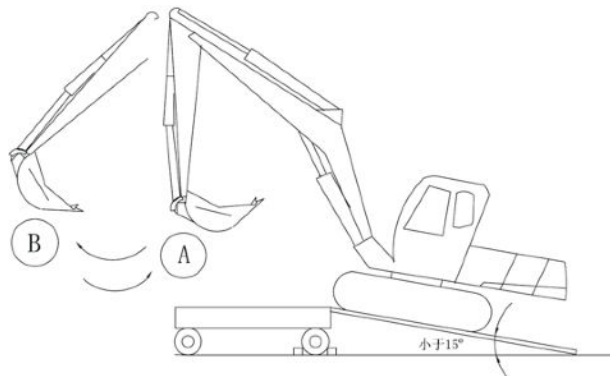

**Warning: Upon completion of the work or the end of the manipulation, the driver should first pull the safety locking lever to lift the left control box to cut off the oil source of the pilot valve before he leaves the seat, to avoid the malfunctions of the machine by the touch of the stick by mistake or unintentionally.**

**Note: Please select the transport vehicles whose size and weight match that provided in this operation manual.**

### 3. Fixing the machine on the transport vehicle

- 1) Adjust the working device.
- 2) Turn off the engine and remove the key from the starter switch.
- 3) Lift the safety locking lever.
- 4) Lock the cab and the engine bonnet.



- 5) Put pads under the both ends of the tracks to prevent the moving of the machine in the transportation, and tether the machine firmly with the wire ropes. Please pay special attention to the fixing of the machine to prevent it from sliding to one side.

### 4. Unloading from the transport vehicle

- 1) Unloading can only be carried out on the solid and flat ground, with a safe distance to the road edge.
- 2) Impose appropriate brake to the transport vehicle, and put pads under the tires to ensure that the transport vehicle cannot move.
- 3) Install a ramp between the truck and the machine, and ensure that the ramps of both sides at the same horizontal surface. The gradient of the ramps should not exceed 15°. Adjust the distance of the ramps to match the track enter.
- 4) Remove the wire ropes used to fix the machine.
- 5) Start the engine. If in the winter, you should do a thorough warm-up operation.
- 6) Put down the safety locking lever.
- 7) Lift the stick and bucket, and raise the bucket.
- 8) Check and make sure that there is no obstruction within the range of the excavator.
- 9) Pull out the platform locking pin, making the platform turn 180 °, the digging device toward the

slope, and the machine on the way forward.

- 10) The excavator walk forward slowly to the top of the stab, and now overhang the stick, making the tracks of the machine dump onto the ramp, and then move the machine slowly to the ground.

## 5. Hoisting the machine

### A. Safety issues

- 1) You can never hoist the machine when someone is on it.
- 2) Ensure that the wire ropes used for hoisting the machine has sufficient strength to withstand the weight of the machine.
- 3) Except the positions provided in the following procedures, do not hoist the machine in any other positions, otherwise the machine will have the risk of losing balance.
- 4) Do not hoist the machine when the upper structure is turning to the side. Before hoisting, you should turn the working device to the side of the sprocket, and make the lower track parallel to the upper structure.
- 5) When raising the machine, keep the machine in balance.
- 6) When the machine is being hoisted, it is very dangerous to walk under the machine, so please do not walk under the machine.

### B. Hoisting procedures - the machine of standard technical specifications

**Note: The hoisting procedures apply to the machine of standard technical specifications. As to the lifting appliance, you should select the special lifting appliance with the lifting ability to meet the weight of the machine.**

When lifting the machine, you should operate according to the following steps on the flat ground.

- 1) Turn the upper structure, making the working device at one end of the sprocket.
- 2) Fully extend the bucket cylinder and stick cylinder, and then make the working device fall to the ground with the boom cylinder.
- 3) Turn off the engine and make sure there is nothing around the cab, and then leave the machine after shutting the cab door and the windows.
- 4) Pass the wire ropes in the front from between the idlers and the tracks to at the back between the driving wheels and the track rollers. You can also pass the wire ropes from below the tracks.
- 5) Adjust the lifting angle of the wire ropes to 30° to 40°, and then lift the machine slowly.
- 6) After the machine leaves the ground, you should check carefully whether the machine is in balance, and then lift the machine slowly.

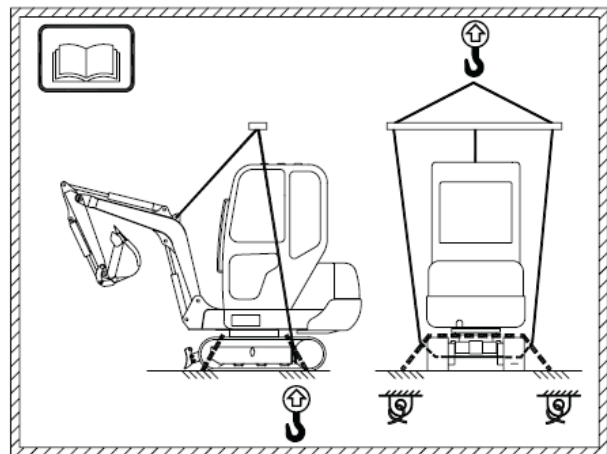

## Operating under the Hot or Cold Climate

### 1. Operating in the cold climate

The cold weather can cause particular problems, so you must pay special attention to the protection to prevent the serious damage of the machine. The maintenance in the cold weather will extend the life of the machine.

- 1) Electrical System: Keep the battery clean, full of power; and check the battery cables and connectors, clean and coat them with a layer of grease to prevent corrosion.
- 2) Lubricant: use the lubricant of suitable viscosity at each junction. Please use the lubricant recommended for this machine.
- 3) Fuel system: check if the fuel supply is suitable for the cold climate. If not, change with the low-viscosity fuel.

Check the water in the fuel system. Cold weather causes the water concentration in the tank, so please check the water in the fuel filter every 50 hours of the operation. If there is no water there, you can extend the inspection cycle. If there is water, check the fuel tank.

- 4) Cooling system: Before operating the machine in cold weather before, check the coolant and adjust the appropriate mix ratio. Use the antifreeze applying to the ambient temperature conditions.
- 5) Working device: Before operating the machine, hang the low file and drive the machine slowly, and then stop the machine to operate the working device for about 10minutes, or until all of the hydraulic cylinders is thought to work normally, After this, you can carried out the operation.

### 2. Operating in the hot climate

To prevent the damage to the machine, please do according to the following terms:

- 1) Make sure that the amount of coolant within the radiator is proper.
- 2) Before the hot season begins, check the radiator. If necessary, replace the coolant.
- 3) Remove all the dirt and fouling on the surface of the radiator and the engine.
- 4) Check the rotation belt of the fan.。
- 5) Use the oil of proper viscosity.
- 6) Use the coolant of proper ratio in the cooling system.
- 7) You should always check the air filter when operating under the poor conditions such as the dusty environment.



## Storage of the Machine

### 1. Preparation before the storage

When the machine need as long-term storage, please do according to the following steps:

- 1) Clean and wash all the parts, then put the machine into the room. If the machine has to be stored outdoors, choose the flat ground and cover up the machine with the drop cloths.
- 2) Have the metal surface of the piston rod coated with a layer of grease. Lubricate all lubrication points.
- 3) Remove the battery for filling and charging, and then store it in the dry ice-free place.
- 4) Exclude the engine oil and fill it with anti-corrosion oil. For the piston engine, the anti-corrosion oil should be L-21260 type. For the winter storage, please use 1 or 2 grade of SAE10W, while for the summer storage, please use SAE30.
- 5) Add 4%-6% the anti-corrosion of the same type to the fuel and make a good mix of both. To prevent the condensation water, the tank should be refilled with such mixed fuel.
- 6) Check the antifreeze performance of the coolant. You can make the antifreeze of it at least -20°C by the method of adding antifreeze. If for the reasons of climate, the coolant does not contain preservatives, corrosion inhibitors should be added (e.g., according to MIL-G4339C, it should contain 5% of the anti-corrosive).
- 7) Start the engine and keep it running more than 15minutes, at different speeds but without load. You also should run the engine to exclude the lubricants of the hydraulic parts and reducer, and the store them with replacing the new oil.
- 8) Close the inlet of the air filter and the outlet of the exhaust pipe. For this position, it is recommended to use the thick plastic and adhesive tape.
- 9) Lock the platform and lift the safety locking lever (lift the left control box), making the sticks and pedals in the locking state.
- 10) Pull the valve used to install the accessories in the locking position. And fit a plug at the elbow.
- 11) Keep the machine clean, and make it stored in a dry place.

**Note: When storing the machine, you should adjust the machine to the position as shown in the right picture to protect the cylinder piston rod and prevent the piston rod from rusting.**

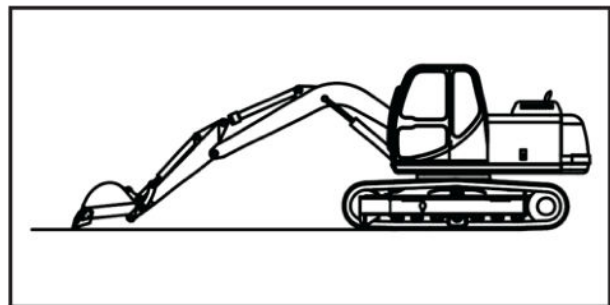

## 2. During storage

- 1) During storage, operate the machine once a month to make the surface of the moving parts attached with a layer of the now film and charge the battery at the same time.
- 2) Run the air conditioning for the machine equipped with the air conditioning.
- 3) Turn the track.



**Warning: If you must carry out the antirust operation to the machine stored indoors, you have to open the doors and windows to promote the air circulation and prevent the gas poisoning.**

## 3. Use recovery after storage

Before using the machine after long-term storage, please do according to the following steps:

- 1) Wipe off the grease coated on the surface of the cylinder piston rod.
- 2) Fill oil and grease to all the parts of the machine.
- 3) After long-term storage, the atmospheric moisture will enter the within the machine. Before or after starting the machine, you have to check the oil of all parts of it. If there is water in the oil, replace all the oil.

- Note:**
- 1) Under the condition of normal climate, the method above introduced can make the excavator in storage for one year. However, after 6 months of the storage, you should run all the parts of the machine without load for 15minutes, and at the same time, fill lubricants to all the parts of it.
  - 2) Before reusing the machine after long-term storage, you have to do the necessary work and all the inspections. After the machine is stored for one year, you also have to exclude the oil in the reducer and the hydraulic circuit and immediately make the replacement.

## Reasons of Technical Failures and Solutions

Failures	Reasons	Solutions
<b>1. The engine cannot start or is difficult to start</b>	● The problem of the starter motor	● Replace or repair the starter motor
	● Insufficient battery charge	● Charge or replace the battery
	● Improper use of the warm-up lines or plugs	● Repair or replace the plugs
	● Incorrect injection time	● Check the injection timing
	● Blockage of the pipeline	● Clear the oil line
	● Blockage of the fuel filter	● Clean or replace the fuel filter
	● Water, dust or air in the fuel system	● Exclude the air and clean the oil lines
	● Dirty or low-pressure fuel injection nozzle	● Repair in the local service center
	● Failure of the fuel pump	● Consult the agents of the company
	● Fuel shortage	● Refuel
	● Blockage of the intake and exhaust system	● Make the intake and exhaust system unimpeded
<b>2. Knock, irregular running or shutdown of the engine.</b>	● A large amount of blow-by gas	● Consult the agents of the company
	● Blockage of the fuel filter	● Clean the fuel filter
	● Dust or air in the fuel system	● Exclude the air and clean the oil lines
	● Fuel filter blockage, dirty or defective nozzle	● Repair in the local service center
	● High-pressure pipeline damage	● Replace the high-pressure pipeline
	● Fuel shortage	● Refuel
	● Unadjustable speed governor connection	● Consult the agents of the company
	● Faulty fuel pump	● consult the agents of the company
	● Incorrect injection timing or the stuck nozzle	● Check the injection timing and the nozzle
<b>3. Power of the engine is reduced</b>	● Fuel mixed with air	● Exclude the air
	● Unsmooth oil supply	● Check and wash
	● Injection timing changes	● Adjust following the value required
	● Bad work of the injector	● Check the working pressure and atomization of fuel injection
	● Blockage of the air filter	● Clean the filter element
	● Incorrect clearance of the intake and exhaust valves or the valve is not sealed	● Adjust the valve clearance
	● Broken air cylinder pad and leakage	● Replace the air cylinder pad
	● Bad work of the fuel pump	● Consult the agents of the company
	● Engine overheating	● Check if the coolant used is correct, if the pump and the belts are too loose, if necessary, repair or replace immediately. And clear the obstructions in the waterway



<b>Failures</b>	<b>Reasons</b>	<b>Solutions</b>
<b>4. Engine overheating</b>	• Coolant level is too low	• Add coolant
	• Failure of the temperature sensor	• Replace the sensor
	• Blockage of the air filter	• Clean the air filter
	• Fan belt is loose or faulty	• Re-tighten or replace
	• Dirt in the cooling system	• Clean the channel
	• Oil of poor quality or too much	• Replace the oil
<b>5. Too low oil pressure</b>	• Engine oil level is too low	• Refuel
	• Blockage of the oil filter	• Clean the oil filter
	• Pipeline leakage	• Re-tighten or replace
	• Temperature of the engine cooling water is too high	• Properly configure coolant mixing ratio, or consult the agents of the company
<b>6 Motor discharges the gray-black smoke</b>	• Fuel of poor quality	• Use the correct fuel
	• Blockage of the air filter	• Replace the filter element
	• Incorrect injection timing	• Adjust following the required value
	• Poor atomization of the nozzle	• Check and replace the parts
<b>7. Motor discharges the white smoke</b>	• Fuel of poor quality	• Use the correct fuel
	• Too much engine oil	• Recover the recommended oil level
	• Incorrect injection timing	• Adjust following the required value
	• Water in the cylinder or in the oil	• Check and replace the oil
<b>8. Battery cannot be charged</b>	• Loose or rusted connection	• Clean or tighten
	• Alternator belt is loose or defective	• Tighten or replace
	• Generator cannot be charged	• Consult the agents of the company
<b>9. Starter does not work or runs slowly</b>	• Loose or rusted connection	• Clean or tighten
	• Insufficient battery charge	• Replace
	• Wires damage	• Consult the agents of the company
<b>10. Running of the engine with the with the alarm indicator on</b>	• Generator failure	• Consult the agents of the company
	• Electronic regulator fault	• Replace
	• Wires failure	• Check and repair
<b>11. Hydraulic system parts run too slowly</b>	• Hydraulic oil is cold	• Operate to raise the temperature
	• Too low pressure of the pilot system	• Consult the agents of the company
	• Use the wrong hydraulic oil	• Use the correct hydraulic oil
	• Engine speed is too low	• Consult the agents of the company

<b>Failures</b>	<b>Reasons</b>	<b>Solutions</b>
<b>12. Hydraulic oil temperature is high</b>	• Use the incorrect hydraulic oil	• Use the correct hydraulic oil
	• Oil lines blockage	• Consult the agents of the company
	• Blockage of the hydraulic oil filter	• Clean or replace
	• Oil pump wear	• Consult the agents of the company
	• Blockage of the oil cooler	• Clean the oil cooler
	• Oil cooler failure	• Consult the agents of the company
	• High pressure of the main safety valve or the rotation system	• Consult the agents of the company
	• The oil is too dirty	• Replace the oil
<b>13. Hydraulic oil emulsion or has foam</b>	• Sensor failure	• Replace
	• Leakage of the pipeline between the tank and the oil pump	• Repair or tighten
	• Use the incorrect hydraulic oil	• Use the correct hydraulic oil
	• Water in the hydraulic oil	• Replace the oil
<b>14. Oil pressure is low or no oil pressure</b>	• The oil level is too low	• Correct the oil level
	• Hydraulic pump damage	• Consult the agents of the company
	• Oil shortage in the system	• Refuel
<b>15. All parts cannot work</b>	• Safety valve failure	• Consult the agents of the company
	• Hydraulic pump damage	• Consult the agents of the company
<b>A. Pump noise</b>	• Hydraulic oil shortage	• Refuel
	• Suction line leakage	• Repair or replace
<b>B. Constant pump noise</b>	• Auxiliary pump damage	• Replace
	• Hydraulic safety control device does not work.	• Check and repair
<b>16. All the cylinders or motors does not work or work weakly</b>	• Hydraulic pump damage	• Consult the agents of the company
	• Main safety valve pressure is lower.	• Readjust the pressure
	• Hydraulic oil level is low.	• Refuel
	• Blockage of the oil filter	• Clean the oil filter
	• Oil seal damage	• Repair or replace
	• Oil spills due to the piston rod damage	• Repair or replace
	• Pilot valve failure	• Replace
	• Breakage or leakage of the pilot pipe	• Repair or replace
<b>17. Two working device do not work</b>	• Oil flushing of the center rotation joint	• Consult the agents of the company
<b>18. One working device does not work</b>	• Walking device damage	• Consult the agents of the company
	• Control structure damage	• Check and repair

<b>Failures</b>	<b>Reasons</b>	<b>Solutions</b>
<b>19. Abnormal waling</b>	• Tracks are too loose or tight	• Readjust
	• Oil pump performance is dropping.	• Consult the agents of the company
	• Track frame deformation	• Repair or replace
	• Track chain with gravel or rock	• Remove and repair
	• Control valve leakage	• Consult the agents of the company
	• Motor performance is dropping	• Consult the agents of the company
<b>20. Abnormal rotation.</b>	• Oil pump performance fell down	• Consult the agents of the company
	• Rotary motor damage	• Consult the agents of the company
	• Pilot valve does not work	• Consult the agents of the company
<b>21. Rotation is of no continuous</b>	• Rotation gears wear	• Consult the agents of the company
	• Rotation bearing and balls damage	• Consult the agents of the company
	• Grease shortage	• Consult the agents of the company
	• Control valve leakage	• Consult the agents of the company
<b>22. Air-conditioning system noise</b>	• Clutch of different directions due to the loose of the electrical connector	• Tight the plug or do the corresponding processing
	• Belts are loose	• Adjust moderately, if damaged, then replace
	• Loose blower fan	• Retighten
	• Blower is not functioning properly	• Repair or replace
	• Electric fan is not functioning properly	• repair or replace
	• Compressor bearing damage	• Replace
	• Tensioning wheel bearing damage	• Replace
<b>23. Air conditioning is not cooling</b>	• Electric line fault	• Repair or replace
	• Air conditioning switch failure	• Repair or replace
	• No refrigerant	• Check, repair and fill the refrigerant
	• System blockage	• Clean or replace
	• Loose or broken belt	• Adjust or replace
	• Expansion valve malfunction	• Clean or replace
	• Compressor is not functioning properly	• Repair or replace
	• Pressure switch failure	• Replace
<b>24. Cooling is of no continuous</b>	• Poor contact of the wires	• Check and repair
	• Belts are too loose	• Adjust the belts properly
	• Improper adjustment of air conditioning refrigeration switch	• Readjust
	• System contains too much water and the internal is of ice blockage	• Replace the drier
	• Electric fan or its relay damage	• Repair or replace

<b>Failures</b>	<b>Reasons</b>	<b>Solutions</b>
<b>25. No meter display</b>	<ul style="list-style-type: none"> <li>Fusing of the starter switch safety plate</li> </ul>	<ul style="list-style-type: none"> <li>Replace with the safety plate of the same size</li> </ul>
	<ul style="list-style-type: none"> <li>Broken starter switch, wiring errors or joint laxity</li> </ul>	<ul style="list-style-type: none"> <li>Replace the switch; Check the lines, tighten the connector</li> </ul>
	<ul style="list-style-type: none"> <li>Power Switch Failure</li> </ul>	<ul style="list-style-type: none"> <li>Replace the power switch; Check the lines, tighten the connector</li> </ul>
	<ul style="list-style-type: none"> <li>Battery connection fault</li> </ul>	<ul style="list-style-type: none"> <li>Check the battery's electric eye, if it is red, replace or charge the battery.</li> </ul>
	<ul style="list-style-type: none"> <li>Storage battery body fault</li> </ul>	<ul style="list-style-type: none"> <li>Check the power of the storage battery. If the red light is on, charge the battery or replace it with another one.</li> </ul>
	<ul style="list-style-type: none"> <li>Fusing of the instrument safety plate</li> </ul>	<ul style="list-style-type: none"> <li>replace with the safety plate of the same size</li> </ul>
	<ul style="list-style-type: none"> <li>Meter body failure</li> </ul>	<ul style="list-style-type: none"> <li>Check the meter connections to know the phenomenon of poor contact; Replaced with new instrument</li> </ul>
<b>26. The engine cannot start.</b>	<ul style="list-style-type: none"> <li>Broken starter switch, wiring errors or joint laxity</li> </ul>	<ul style="list-style-type: none"> <li>Replace the switch; Check the lines, tighten the connector</li> </ul>
	<ul style="list-style-type: none"> <li>Busing of the start motor safety plate</li> </ul>	<ul style="list-style-type: none"> <li>Replace with the safety plate of the same size</li> </ul>
	<ul style="list-style-type: none"> <li>The starter relay is broken</li> </ul>	<ul style="list-style-type: none"> <li>Check the relay connector, eliminating the poor connection; Replace the starter relay.</li> </ul>
<b>Starter does not run</b>	<ul style="list-style-type: none"> <li>Poor connection of the starter wires</li> </ul>	<ul style="list-style-type: none"> <li>Clean and tighten the contact points</li> </ul>
	<ul style="list-style-type: none"> <li>Insufficient battery charge</li> </ul>	<ul style="list-style-type: none"> <li>Charge or replace the battery</li> </ul>
	<ul style="list-style-type: none"> <li>Open circuit of the engine itself</li> </ul>	<ul style="list-style-type: none"> <li>Repair or replace the starter motor</li> </ul>
<b>Starter motor starts weakly</b>	<ul style="list-style-type: none"> <li>Poor connection of the starter switch</li> </ul>	<ul style="list-style-type: none"> <li>Repair or replace the starter switch</li> </ul>
	<ul style="list-style-type: none"> <li>Poor connection of the motor main line</li> </ul>	<ul style="list-style-type: none"> <li>Clean and tighten the electrical contact point</li> </ul>
	<ul style="list-style-type: none"> <li>Electromagnetic switch lines are loose</li> </ul>	<ul style="list-style-type: none"> <li>Tighten electrical contact points</li> </ul>
	<ul style="list-style-type: none"> <li>Insufficient battery charge</li> </ul>	<ul style="list-style-type: none"> <li>Charge the battery</li> </ul>
<b>27. No preheating</b>	<ul style="list-style-type: none"> <li>Starter switch breakage, wiring errors or joint laxity</li> </ul>	<ul style="list-style-type: none"> <li>Replace the switch; Check the lines, and tighten the connector</li> </ul>
	<ul style="list-style-type: none"> <li>Fusing of the preheat safety chip</li> </ul>	<ul style="list-style-type: none"> <li>Replace with the safety chip of the same size</li> </ul>
	<ul style="list-style-type: none"> <li>Preheat relay breakage</li> </ul>	<ul style="list-style-type: none"> <li>Check the relay connector, eliminating the poor connection; Replace the starter relay.</li> </ul>
	<ul style="list-style-type: none"> <li>Insufficient battery power</li> </ul>	<ul style="list-style-type: none"> <li>Replay with the new battery or charge the old battery</li> </ul>
<b>28. Meter is not working properly</b>	<ul style="list-style-type: none"> <li>Instrument panel display is abnormal</li> </ul>	<ul style="list-style-type: none"> <li>If the LCD panel is broken, replace with the new instrument.</li> </ul>
	<ul style="list-style-type: none"> <li>Key instrument is abnormal.</li> </ul>	<ul style="list-style-type: none"> <li>If the button is broken, replace with a new one</li> </ul>



<ul style="list-style-type: none"> <li>• The running speed value display of instrument is abnormal.</li> </ul>	<ul style="list-style-type: none"> <li>• If the instrument is broken, replace it.</li> <li>• If the sensor is broken, or the connection is poor, check the wiring.</li> <li>• Check if the number of flywheel teeth set by instrument is correct.</li> </ul>
<ul style="list-style-type: none"> <li>• The oil level value display of the instrument is abnormal.</li> </ul>	<ul style="list-style-type: none"> <li>• If the instrument is broken, replace it.</li> <li>• If the oil level sensor is broken or the connection is poor, check the wiring.</li> </ul>

Failures	Reasons	Solutions
	<ul style="list-style-type: none"> <li>Instrument display of the hydraulic temperature is abnormal</li> </ul>	<ul style="list-style-type: none"> <li>If the instrument is broken, replace it. If the oil temperature sensor is broken or the connection is poor, check the wirings.</li> </ul>
	<ul style="list-style-type: none"> <li>Instrument display of the water temperature is abnormal</li> </ul>	<ul style="list-style-type: none"> <li>If the instrument is broken, replace it. If the water temperature sensor is broken or the connection is poor, check the wirings.</li> </ul>
	<ul style="list-style-type: none"> <li>Instrument display of the oil pressure is abnormal</li> </ul>	<ul style="list-style-type: none"> <li>If the instrument is broken, replace it. If the oil pressure sensor is broken or the connection is poor, check the wirings.</li> </ul>
	<ul style="list-style-type: none"> <li>Air filter and oil filter alarm malfunction</li> </ul>	<ul style="list-style-type: none"> <li>if the instrument is broken, replace it. If the oil pressure sensor is broken or the connection is poor, check the wirings.</li> </ul>
<b>29. Other appliances working abnormally</b>	<ul style="list-style-type: none"> <li>Electric fan does not work.</li> </ul>	<ul style="list-style-type: none"> <li>If the electric fan is broken, replace it. Check the connector to eliminate the poor connection. If the electric fan switch is broken, replace the switch,</li> </ul>
	<ul style="list-style-type: none"> <li>Work lights do not work.</li> </ul>	<ul style="list-style-type: none"> <li>If the work light is broken, replace with a new one of the same size. Check the connector to eliminate the poor connection. If the work light switch is broken, replace the switch,</li> </ul>
	<ul style="list-style-type: none"> <li>Electric horn does not work.</li> </ul>	<ul style="list-style-type: none"> <li>If the electric horn is broken, replace it. Check the connector to eliminate the poor connection. If the electric horn switch is broken, replace the switch,</li> </ul>
	<ul style="list-style-type: none"> <li>Dome light of the cab does not work</li> </ul>	<ul style="list-style-type: none"> <li>If the dome light is broken, replace it. Check the connector to eliminate the poor connection. If the dome light switch is broken, replace the switch,</li> </ul>
	<ul style="list-style-type: none"> <li>Radio does not work normally.</li> </ul>	<ul style="list-style-type: none"> <li>if the radio is broken, replace with a new one. Check if the radio antenna is intact, the wiring is normal, and the power plug connector contact is good. If the speaker wirings are not good, check the speaker wirings.</li> </ul>
	<ul style="list-style-type: none"> <li>Wiper does not work properly.</li> </ul>	<ul style="list-style-type: none"> <li>If the wiper is broken, replace it. Check the connector to eliminate the poor connection. If the wiper switch is broken, replace the switch,</li> </ul>

**5**

---

**Maintenance**

## Maintenance Knowledge

### New machines running-in

The first 100hours are the run-in period, during which it should be used carefully, without letting the machine engage in the work of heavy load or high intensity. During the first 50 hours of the run-in period, it is just allowed to withstand 80% of the workload. Whether the machine is used properly during the run-in period affects the life of the machine.

After the first 50hours of work, please do the first inspection and maintenance based on the table of inspection and maintenance, replacing the related oil and filter. At the same time, please check the pollution of the hydraulic oil, whose value cannot exceed NAS9 level, otherwise replace with the new hydraulic oil.

When the hydraulic system is not working, you cannot have the working device running at a high speed. Only when the temperature of the hydraulic oil exceeds 20°C, the working device can be operated.

### Construction in a dusty site

When working in a dusty workplace, please do according to the following steps:

- Always check if the air filter is blocked with the air filter sensor.
- Clean the radiator core frequently to prevent clogging.
- Clean and replace the fuel filter element frequently.
- Clean the electric parts, especially the start motor and the alternator to prevent the accumulation of dust.
- When checking the machine or changing the oil, you should move the machine to the place without dust to prevent the dust from entering the oil.

### Oil and filter element

Please use the clean oil and grease, and do not let the contamination enter the oil container.

After changing the oil or replacing the filter element, you should check if there is swarf or impurities in the oil and filter element. If large number of metal particles or impurities is found, you are required to report to the supervisors and take appropriate measures.

Do not mix different grades the oil of different grades. If you want to add the oil of different grades, you have to drain the old oil with the replacement of the oil of new grades.

### Timer reading

View the timer on the dashboard, and see if it is time for maintenance based on the hours of work.

### Use the genuine parts

The use of the genuine Yuchai parts is an important factor to ensure the normal wok of the machine and extend the life of the machine.

## **Waste disposal**

Promote environmental protection, paying particular attention to the waste treatment:

- Put the emissions oil of the engine into the container, but not directly dump it into the ground, or into the sewer, or ditch, river, ocean or lake.
- When handling the hazardous materials, such as oil, fuel, coolant, antifreeze, plastic parts, solvents, filter element, battery and other hazardous substances, you should comply with environmental regulations.

## **Prevent the things falling into the machine**

- When you are open the tank nozzle to check, be careful not to make the bolt, nut, gasket or tool falls into the machine. If these things fall into the machine, the machine will be caused damage and failure, which may lead to the accidents. If something fell into the machine, please immediately take it out.
- Before or after checking, you have to make an inventory of the tools and parts brought, to make sure that nothing falls into the machine.

## **Regular inspection and maintenance**

Regular inspection and maintenance according to the items listed in “Regular inspection and maintenance table” is an important prerequisite to ensure the proper work of the machine and to prolong the service life of it. You must do this complying with the inspection and maintenance cycles.

## **Rechecking after the inspection and maintenance**

If after each inspection and maintenance, you do not recheck, unexpected failures will occur, leading to severe sadness or damage. You should recheck the following items:

- Whether certain parts that should be checked and maintained are omitted.
- Whether all the inspections and maintenance projects have been carried out properly.
- Check if there are tools or parts falling into the machine. If the tools or parts fall into the machine and are stuck in the linkage, it will brings severe danger.
- Check around the machine to see if there is water leakage or oil leakage, and if all the bolts have been tightened.

## Maintenance Summary

### Lubricating oil

- You should use the oil whose level and temperature meet the requirement of the “oil selection table” in this operation manual. Within the prescribed time, even if the oil is not dirty, it also should be replaced.
- Please prevent impurities (water, metal particles and dust, etc.) into the lubricating oil. Most problems of the machine are caused by the impurities entering it.
- Do not mix together the oil of different grades or brands.
- Refuel according to the provisions. Too much or too little oil will cause oil breakdown.
- When changing the oil, make sure to replace the associated filter element, especially when changing the oil filter element, before the installation, please add to the new filter element with the fresh and clean oil which meets the requirement.

### Fuel

- When storing or adding the fuel, you should be particularly careful to prevent the impurities from entering the fuel.
- Be sure to use the fuel provided in the “Oil Select Table” of this operation manual. The fuel should be selected based on the ambient temperature, because if the temperature is very low, it is easy for the oil to freeze (especially below minus 15 °C (5°F) ). Therefore, you must replace with the oil matching to the ambient temperature.
- To prevent moisture in the air condensing into water in the fuel tank, the fuel tank should be filled fully after the end of the work every day.
- Before starting the engine or 10minutes after filling the fuel, please discharge the sediment or water in the tank.
- If the engine has run out of fuel, or if you have replaced the filter element, the air in the oil lines must be excluded.

### Grease

- Grease is used to prevent distortion and noise at the connection.
- After long-term use, if any parts do not seem flexible or have noise, please add grease to them.
- Wipe the old grease squeezed out when filling grease.
- Remember to wipe the old grease everywhere. The and or dust sticking to the grease will cause the wear of the rotating components.

### Coolant

- Antifreeze must be used in any climate.
- Check the coolant level according to the provisions. If it is not enough, please immediately add it. Coolant shortage will cause the engine overheating.
- According to the ambient temperature, configure coolant and antifreeze of applying mixing ratio.
- Do not add coolant when the engine is overheating or has not been cooled.

## **Filter element**

- Replace all of the filter elements regularly. However, when operating in harsh conditions, you should replace the filter element in a shorter period according to the oil or fuel (sulfur content) being used.
- Do not reuse the cleaned filter elements (filter-element type). Please replace with the new one.
- When replacing the filter element, check if there are metal particles absorbed on the old filter element. If any, please contact Yuchai dealer.
- Before using, do not open the packaging of spare filters.

## **Hydraulic system**

- The system is under high temperature in the work or after work, and it is in the high pressure state when you are operation. Therefore, when you are to do inspections and maintenance to the hydraulic system, please wait until the temperature falls down and the pressure in the hydraulic lines is released.
- Do not stand in front of the parts when you are releasing the bolts, screws or hose connectors. Before demolition, please release gradually to make the pressure inside released.
- When you do inspection and maintenance for the hydraulic oil lines, be sure to exhaust the air to release the internal pressure.
- Hydraulic system inspection and maintenance include: checking the hydraulic oil level, replacing the filter element and adding hydraulic oil.
- When removing the high-pressure pipe, check whether the O-ring is damaged. If it is damaged, please replace immediately.
- When removing the parts with O-ring or sealed with gasket, you have to clean the mounting surface and replace with new parts.
- When installing the hose, you are not allowed to twist the hose or bend it into a small diameter of the circle, because this will damage the hose, and significantly reduce the service life of it.

## **Electrical system**

- That the electrical is wetted or the wire insulation is damaged is very dangerous, which will cause electric leakage and machine malfunction, so do not wash inside the cab with water. When washing the machine, be careful not to let water enter the electrical components.
- Maintenance of the electrical system includes: battery level check and maintenance; replacement of light bulbs; replacement of fuses and relays and so on.
- Do not install any electronic components other than those required by Yuchai.
- When working on the machine, you should carefully clean the electrical system to prevent corrosion.
- When installing the cab cooling fan or other electrical equipments, you should connect it to the dedicated power connector. The power selected cannot be connected to the fuse, starter switch or the battery relay.
- During electric welding work on the machine, it needs the professional electric technician to disconnect the connectors of the electric components (like monitor, controller, engine ECU, etc.) And disassemble the negative cable of the battery before working, so as to avoid damaging the electric components of the machine.

## Parts of Mandatory Replacement

With the working time accumulation of the machine, some components playing an important role in safety, mainly include some oil hose, of which the material will change, and prone to aging, wear or deterioration, not only affecting the play of its normal functions, but also forming a potential risk to the safety. However, it is not easy to judge these phenomena; therefore, these parts must be replaced forcefully after the required using time limit.

If there is something abnormal with these parts before the using time limit, you also have to repair or replace them immediately. When replacing the hoses, please replace the appropriate seals at the same time.



## Oil Selection Table

Choose the applicable fuel according to the ambient temperature, working conditions and other factors. The oil to be used must meet the following requirements:

	Lube or Fuel	Use temperature	Viscosity	Recommended replacement oil
<b>Lube of the engine</b>	Chilliness area:CH15W/40 General area:CH5W/30	-15°C~+40°C -25°C~+30°C		
<b>Hydraulic oil</b>	Low temperature region: HS46+ General area:DTE25	-35°Cupwards -21°Cupwards	(When it is 40°C) 41.5-50.5mm <sup>2</sup> /s	
<b>Lube of the driving reducer</b>	Overload use the gear oil (GL-5)	Winter/summer		SAE80W/90
<b>Lube of the rotating reducer</b>	Overload use the gear oil (GL-5)	Winter/summer		
<b>Lube of the guide wheel/carrier wheel</b>	Vehicle oil Hz-23 lube	All the Temperatures	(When it is 50°C) 20 ~25 centistokes	
<b>Lubricating oil</b>	Lithium molybdenum disulfide-based Lubricating grease (3#)	-20°C~160°C		
<b>Fuel</b>	Summer: 0#light diesel oil Winter: -10# light diesel oil -20# light diesel oil -30# light diesel oil	>0°C 0°C~-5°C -5°C~-15°C -15°C~-28°C		
<b>Coolant (Ethylene glycol type)</b>	T225-1996 -25# -35# -45#	>-15°C >-25°C >-35°C		

- Oil capacity data**

Category	Unit	Value
Fuel Tank	Liter	500
Hydraulic Tank	Liter	264

## Tightening Torque

The following table provides tightening torque for all kinds of bolts, nuts installed on the machine. If the bolt or nut is not tightened to the specified torque, the parts tightened or linked by it will be loosen or even damaged, leading to the machine failure or impacting on the operations.

### Tightening torque of the general parts

Bolt strength grade	Yield strength N/mm <sup>2</sup>	Bolt nominal diameter mm							
		6	8	10	12	14	16	18	20
		Tightening torque Nm							
8.8	640	9~12	22~30	45~59	78~104	124~165	193~257	264~354	376~502
10.9	900	13~16	30~36	65~78	110~130	180~210	280~330	380~450	540~650
12.9	1080	16~21	38~51	75~100	131~175	209~278	326~434	448~597	635~847

Bolt strength grade	Yield strength N/mm <sup>2</sup>	Bolt nominal diameter mm						
		22	24	27	30	33	36	39
		Tightening torque Nm						
8.8	640	512~683	651~868	952~1269	1293~1723	1759~2345	2259~3012	2923~3898
10.9	900	740~880	940~1120	1400~1650	1700~2000	2473~3298	2800~3350	4111~5481
12.9	1080	864~1152	1098~1461	1606~2142	2181~2908	2968~3958	3812~5082	4933~6577

## Tightening torque of the hydraulic hose

Metric threaded rotating nut			
Metric thread	Pipe OD (outer diameter)	Nm	
		Nominal torque	Min./max
M12X1.5	6	20	15~25
M14x1.5	8	38	30~45
M16X1.5	8 10	45	38~52
M18x1.5	10 12	51	43~85
M20X1.5	12	58	50~65
M22X1.5	14 15	74	60~88
M24X1.5	16	74	60~88
M26X1.5	18	105	85~25
M30X2	20 22	135	115~155
M36X2	25 28	166	140~192
M42X2	30	240	210~270
M45X2	35	290	255~325
M52X2	38 42	330	280~380

## Tightening torque of the hydraulic hose

BSP thread and rotating nut		
BSPP thread	Nm	
	Metric torque	Min./max
G1/4	20	15~25
G3/8	34	27~41
G1/2	60	42~76
G5/8	69	44~94
G3/4	115	95~135
G1	140	115~165
G1.1/4	210	140~280
G1.1/2	290	215~365
G2	400	300~500

ORFS rotating nut			
UNF thread	Lineation specification	Nm	
		Min	Max
9/16~18	-4	14	16
11/16~16	-6	24	27
13/16~16	-8	43	47
1-14	-10	60	68
1.3/16~12	-12	90	95
1.3/16~12	-14	90	95
1.7/16~12	-16	125	135
1.11/16~12	-20	170	190
2-12	-24	200	225

## Regular Inspection and Maintenance Table

Carry out regular inspection and maintenance for the machine according to the following table and combined with the working time indicated on the engine timer. If the working conditions of the machine is very poor or the work intensity is very large, or the machine is equipped with the hydraulic hammer and other accessories, the inspection and maintenance cycle should be lessened.

Number	Page number	Contents of inspection and maintenance	Maintenance cycle (total number of the working hour)					
			10	50	100	250	500	1000
1		<b>Routine examination</b>						
		• Whether the engine oil, water or fuel leaks	▲					
		• Appearance of mechanical parts and hoses	▲					
		• Bolts and hydraulic fittings fixed conditions	▲					
		• Manipulation parts, work lights and indicators conditions	▲					
		• Working conditions of the diesel engine	▲					
2		<b>Engine fuel system</b>						
		• Checking the oil level and filling	▲					
		• Discharging condensate water and impurities			▲			
		• Cleaning the tank				▲		
		• Checking the injection pressure					▲	
		• Replace the filter elements		☆		▲		
3		<b>Engine cooling system</b>						
		• Checking the status of the rubber hose and clamps	▲					
		• Checking the coolant level	▲					
		• Cleaning the radiator heat sink					▲	
		• Replacing the coolant		☆				■
		• Checking the concentration of the coolant	▲					
4		<b>Engine lubrication system and other</b>						
		• Checking the oil level(if required, it shall be added)	▲					
		• Oil replacement		☆		▲		
		• Replacing the oil filter element		☆		▲		
		• Checking the tension degree of the fan belt		☆	▲			
		• Checking the valve clearance					☆	▲

	<ul style="list-style-type: none"> <li>• Checking the fastening of the cylinder cover</li> </ul>					☆	▲
	<ul style="list-style-type: none"> <li>• Checking the fastening of the engine support</li> </ul>		☆			▲	

## Regular Inspection and Maintenance Table (continued)

Number	Page number	Contents of inspection and maintenance	Maintenance cycle (total number of the working hour)						
			10	50	100	250	500	1000	1500
5		<b>Engine intake system</b>							
		• Emptying cans of dust	▲						
		• Cleaning the air filter element			▲				
		• Replacing the air filter element					▲		
6		<b>Hydraulic System</b>							
		• Checking the hydraulic oil level (if required, it shall be added)	▲						
		• Excluding water and dirt in the tank				▲			
		• Replacing the hydraulic oil and wash the oil filter						☆	▲
		• Replacing the filter element of the hydraulic return oil line and pilot line				☆	▲		
• Checking the pressure of the system					▲				
7		<b>Battery</b>							
		• Checking the electrolyte level		▲					
		• Checking the acidity and charging status					▲		
8		<b>Reducer</b>							
		• Checking the oil level and oiling				▲			
		• Replacing the oil				☆	▲		
		• Checking the gear bolts tightening torque		☆			▲		
9		<b>Track</b>							
		• Checking and adjusting the tension status of the tracks	▲						
10		<b>Supporting wheels, under rollers, and idlers</b>							
		• Checking the tightening torque of supporting wheels		☆			▲		
		• Checking the oil level of the rollers and idlers						▲	
11		<b>Lubricating</b>							
		• Adding lubricating oil to each lubrication point		▲					



Items following the normal cycle



Items in the first maintenance



Items in every spring and autumn





## Routine Examination

Every day or every 10 hours, do the general routine examination for the machine.

- 1) In the leak inspection, check whether there is leakage of engine oil, water and fuel of all the parts.
- 2) Check whether the elastic connections and the attachments have been scratched, broken or deformed.
- 3) Check the fixing and connecting of the hydraulic device.
- 4) Check the appearance of mechanical parts.
- 5) Check the working status of the operation equipment, the control indicators and any other indicators.
- 6) Check the working situation of the engine: if the exhaust color is normal, if there is abnormal noise, and know exactly the location of the abnormal sound.

# Engine Fuel System

## Maintenance instructions

Fuel tank capacity.....	500 liters
Oil level inspection .....	every 10 hours
Excluding water and impurities from the tank.....	every 100 hours
Cleaning the tank .....	every 250 hours
Injection pressure inspection.....	every 500 hours
Replacing the fuel filter element.....	every 250 hours

### 1. Checking the oil level and refueling

Check the oil level through the oil sign on the side of the tank or the display on the instrument cluster in the right front of the cab, once every day or once every ten hours.

In order to avoid the formation of condensation water, the tank should be filled up after work every day. The oil filler is located in front of fuel – hydraulic tank.

#### A. Fueling directly

Open the filler cap of the fuel tank, and pour the fuel into the filler.

#### B. Using oil pumps

After put the filling tube into the oil barrel, press the switch "-", and the oil pump will suck automatically the oil into the tank. When the tank is full, press the switch "O", and stop oiling.

### 2. Excluding water and impurities from the tank

As to the condensation water and sediment removal, you should do this once every 100 hours.

Open the oil charge valve to make the condensation water and sediment flow out. Once the fuel flows out, replace the drain plug. The cycle of emissions of the condensation water can be redefined by the users themselves depending on the quality of the fuel.

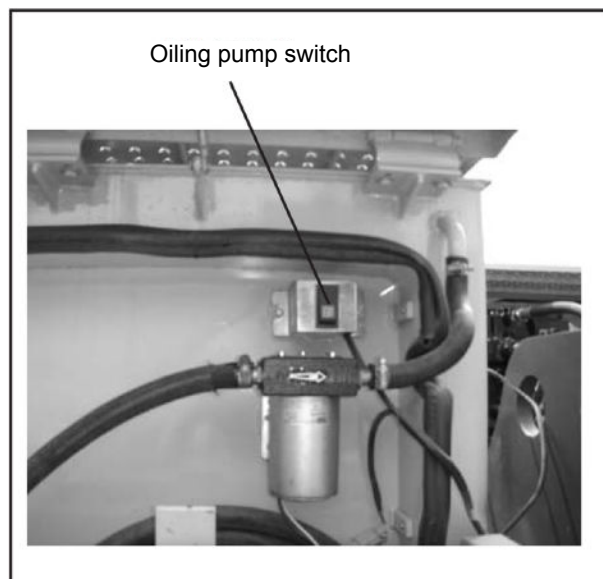
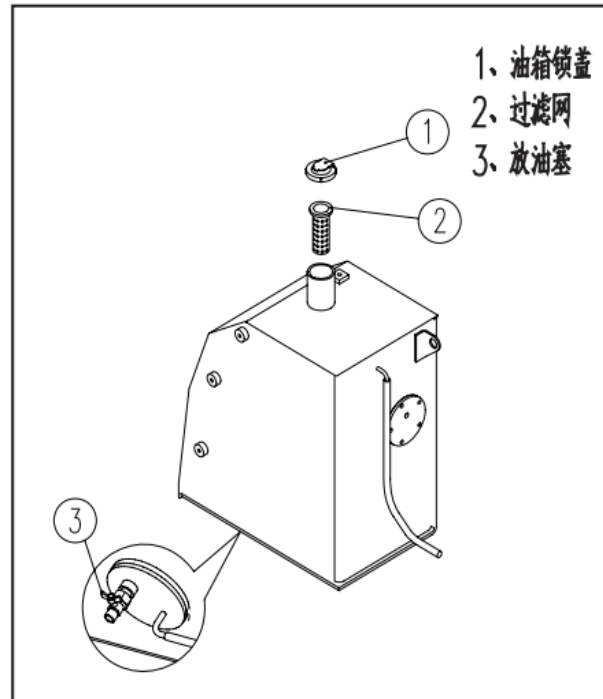



### 3. Cleaning fuel tank

Clean once every 250 hours.

- 1) Prepare a container for the fuel discharged
- 2) Remove the oil discharge valve and the filter located in the filler. Fill up the half of the tank and discharge again.
- 3) Clean the fuel filter and put it back.
- 4) Replace the drain plug and fill the fuel through the filter in the filler.
- 5) Exclude the air in the oil lines.

**Note: When rinse the inside of the tank, do not use trichloroethylene and you can only use diesel.**

### 4. Checking fuel injection pressure

Check every 500 hours!

Fuel injection pressure should be checked periodically according to the maintenance table. And adjust the injection pressure when necessary. This check should be done by the organization authorized by the company!

Work efficiency of the engine depends on the work condition of the injection nozzle, so it should be maintained periodically to ensure its normal working.

For the better use of the engine by the excavator driver, attention should be paid to the following phenomena that indicate bad nozzle working:

- A. Knocking sound of one or more cylinder; B. Overheating of engine; C. Reduction of efficiency; D. Black exhaust; E. Increased fuel consumption

The above phenomena may be caused by the following reasons, so check should be done:

A. Bad sealing of air intake and outtake valves; B. Incorrect injection nozzle adjustment; C. Dirty or damaged fuel filter; D. Bad fuel quality;

E. Water in the fuel; F. Dirty or blocked air filter.

### 5. Air removal in the fuel circuit

If you do not intend to make the tank empty and make the air flow into the fuel circuit during replacing the fuel filter element, disconnect the fuel line or cleaning the fuel filter, then you should exclude all the air before restarting the engine.

Please operate according to the engine use manual of the machine.



**Warning: pressure of the fuel in the high pressure fuel tube is so high that it can penetrate skin and may cause serious personal injury. Therefore gloves and protective clothes should be dressed before operation.**

## 6. Diesel pre-filter (diesel strainer)

After the first 50 hours of the new machine, it should be replaced for the first time. And then, replace the filter element every 250 hours (see the section of "Replacing the fuel filter element" in the following).

Discharge the water and sediment in the separator every day.

- 1) After turning off the machine, open the drain valve by hand, turn the valve knob counter-clockwise about three times and a half, until the valve falls down 25.4mm (1 in), and then start discharging.
- 2) Discharge the water in the separator, until the clean fuel can be seen.
- 3) When close the valve, turn the valve clockwise until it is tightened by hand.

**Note: When closing the valve, do not have the valve too tightened.**

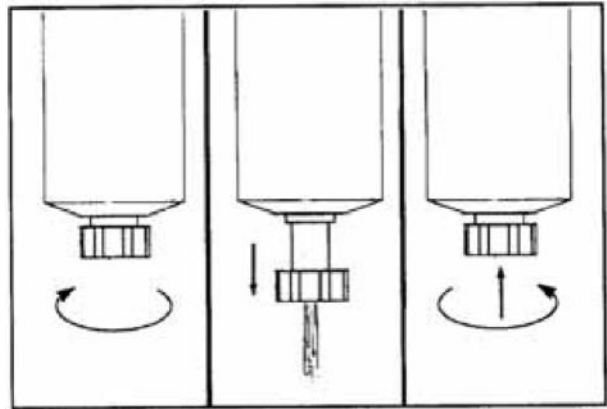

Turn the valve anticlockwise    The valve will get lowered  
Turn clockwise

## 7. Replace the fuel filter element

After the first 50 hours of the new machine, it should be replaced for the first time. And then, replace the filter element every 250 hours or 6 months. Please use the genuine filter element for replacement.

- 1) Remove the fuel filter;
- 2) Clean the gasket surface of the filter seat with a lint-free cloth;
- 3) Waste the O-ring;

**Note: Check if there is old seal sticking to the filter seat, if any, it will cause oil spills.**

- 5) Fill up the new filter with the new fuel, and lubricate the O-ring with the clean oil.

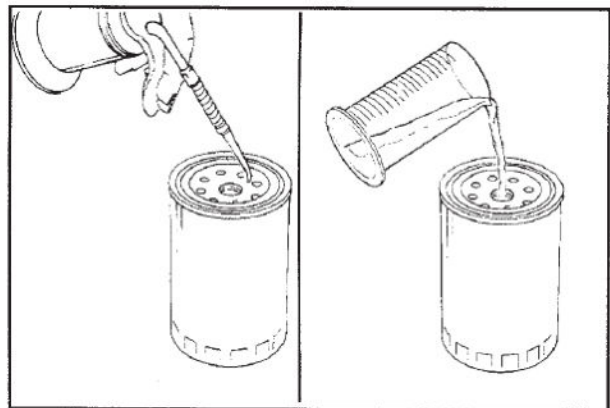

- 6) Install the fuel filter according to the requirement of the manufactures.

**Note: To reduce the possibility of fuel leaks, you should ensure that the fuel filter is installed tighten, but not over-tighten, which will damage the fuel filter.**

- 7) After replacing the filter element, start the engine and check if the filter sealing surface has oil spills.

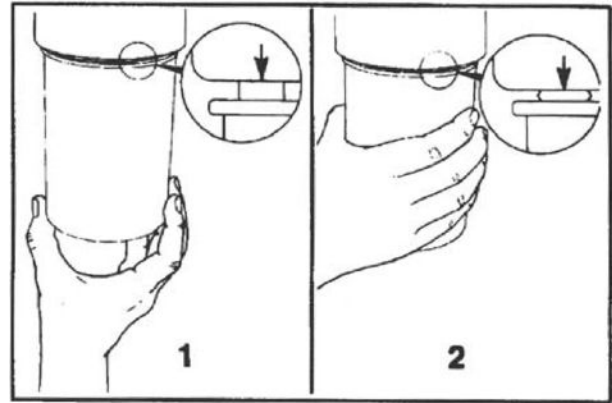

# Engine Cooling System

## Maintenance instructions

The coolant level inspection .....	every day or every 10 hours
Checking the state of the rubber hose and clamps .....	every day or every 10 hours
Cleaning the radiator blade .....	every 500 working hours
Coolant replacement .....	each autumn and each summer
Checking the coolant concentration .....	every day or every 10 hours

### 1. Checking the coolant level

Before the new machine is used, you should check the coolant level in the radiator, and later on, check it once every day or every 10 working hours.

Remove the radiator (radiator) cap, and check the coolant level.

When the engine is at cold state, liquid level of coolant is between the highest and lowest water level.

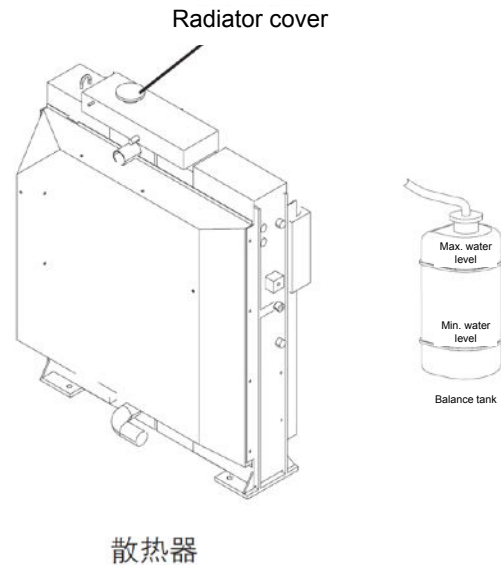

**Warning:** When you are unscrewing the radiator cap, the hot coolant will spray out. The method of unscrewing the cap: making the cap slightly loose to let the pressure fully released. If you screw the cap quickly, the coolant will spray out, which may cause personal injury.

### 2. Checking the status of the rubber







### 3. Cleaning and checking the radiator blade

Clean it every 500 hours.

The dust accumulating on the surface of the radiator (radiator) will affect the cooling effect, so it must be cleaned promptly.

Open the engine hood; blow out the dust or leaves and other debris on the oil coolant blocking the radiator blade with high pressure water or compressed air. Also, clean the filter before the oil is cooled. For the machine equipped with an air conditioner, the condenser film should also be cleaned.



**Warning: If the compressed air, high pressure water and steam directly hit the body, or when using them to blow off the dust or dirt, there is risk of serious injury, so, please remember to wear goggles, dust masks and other protective masks.**

Note: To prevent damage to the heat sink, the distance between the nozzle of the high water or compressed air and the radiator (radiator) surface should be greater than 500mm, because the damaged heat sink will create leaks or overheating. Check the heat sink every day in the dusty worksite, without the limitation of the maintenance cycle.

### 4. Coolant replacement

After the first 50 working hours, it should be changed for the first time, and late on, replace it twice a year, once in spring, and once in autumn.

- 1) Remove the radiator (radiator) cap, and twist the valve open to make the coolant flow out;
- 2) Clean the cooling circuits, close the drain valve, fill with the special cleaning fluid, and then start the engine. After the engine runs for 10minutes at low speed, shun the engine down and release the leaning fluid.
- 3) Re-close the drain valve.
- 4) Fill up with the coolant and make the engine idling for several minutes, making entire cooling circuit full of the coolant.
- 5) Check the coolant level, and add the coolant.

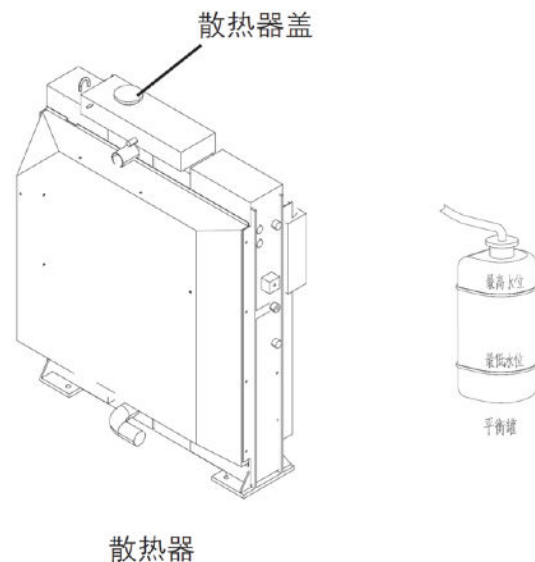

**Warning: Do not open the radiator cap from the heat engine (water tank). You should not open the radiator before the temperature of the coolant drops to below 50°C; otherwise the exhaust of the hot coolant or the steam may cause injury.**

## 5. Checking the coolant concentration

Before the start of the cold season, you have to check the coolant concentration. Coolant can work at the ambient temperature of  $-35^{\circ}\text{C}$ . If the ambient temperature is lower, the proportion of the antifreeze should be increased.



**Warning: The coolant is toxic. So prevent children and pets from contacting with the coolant. If the coolant is not used any longer, the disposal of it should be in accordance with the local environmental regulations.**



**Warning: Antifreeze must be used under any climate.**

**Do not just use water as coolant. Otherwise, it will be damaged because of corrosion.**

**Water in the river contains large amounts of calcium and other impurities. If the river water is used, the scale will be formed, adhering to the engine cooling water and the heat sink, which will result in heat exchanger failure and overheating. If the antifreeze gets into somebody's eyes, immediately wash with water, and promptly sent him to hospital for treatment.**

# Engine Lubrication System

## Maintenance instructions

Oil volume.....	19 liters
Checking the oil level .....	every 10 working hours or every day
Replacing the oil or the oil filter element .....	every 250 working hours

### 1. Checking the oil level

Before the new machine is used, check the oil level once, and later on, check it every 10 working hours.

- 1) Stop the excavator on the flat ground and make the engine shut down.
- 2) Open engine hood, remove the oil gauge and observe the stick position on it. The oil should be at between the two marks the lowest (L) and highest (H).
- 3) If necessary, you can refuel from the filler to make the oil level reach the specified value.

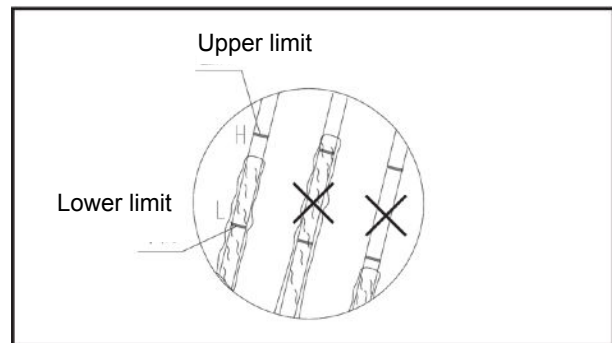

**Warning:** After turning off the engine, the parts and the oil are still in the high temperature and will cause serious burns. Therefore, the maintenance must be carried out after the oil temperature has dropped.

### 2. Replacing the engine oil

Replace it for the first time after the first 50 working hours of the new machine, and later on, it should be replaced every 250 working hours.

- 1) Stop the excavator on the flat and shut down the engine, letting the hot oil out.
- 2) Remove the oil drain plug to make all the oil flow out.



**Avoid inhalation of oil vapors, swallowing the oil, and prolonged exposure to the used motor oil.**

- 3) Clean and re-install the oil drain plug. If the seal is damaged, replace it.
- 4) Open the filling hole.
- 5) Re-inject the new oil, until the oil level reaches the position of greatest mark "H" on the oil gauge.
- 6) Cover the oiling hole, and make the engine idling for five minutes.
- 7) 10-20 minutes after the shut sown of the engine, check the oil level, if necessary, add the oil.

### 3. Replacing the engine oil filter element

Clean it for the first time after the first working hours of the new machine, and after this, clean or replace it every 250 working hours.

#### Oil filter replacement

- 1) Clean the area around the filter, remove the oil filter, and clean the surface of the gasket seat on the filter seat ;
- 2) Lubricate the two gaskets in the oil filter;
- 3) Coat the gasket surface with a layer of oil before install the oil filter;
- 4) Install the oil filter according to the oil filter manufacturer's specifications;
- 5) Run the engine at low idle to check if the oil filter has oil spills;
- 6) Turn off the engine, and wait for 15minutes to make the oil in the parts of the engine fully return;
- 7) Check the oil level, and if necessary, add oil to make the oil level reach the position of highest "H" mark on the oil gauge.

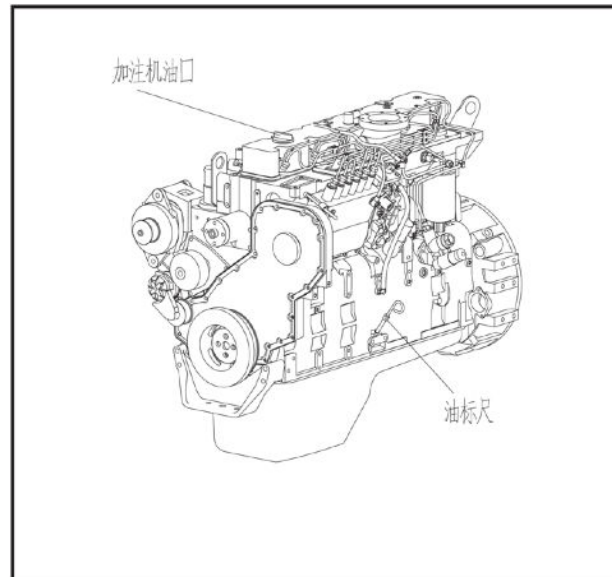
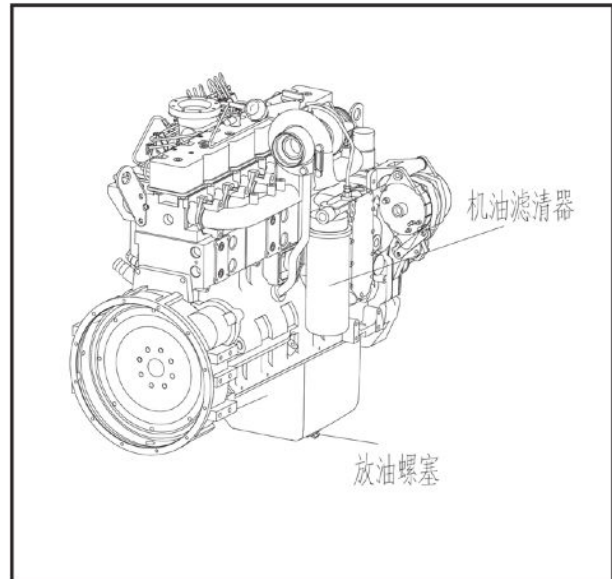

## Engine Intake System

### Maintenance instructions

Air filter element cleaning cycle .....every 100 working hours

Air filter element replacement cycle .....every 500 working hours

### Checking of air intake pipeline

Check every day whether the air intake tubes are worn or damaged, clip loosen or other phenomena that will cause damage of the engine.

If necessary, replace the damaged tubes, and tighten the loose clips to ensure non air leakage of the air intake system.

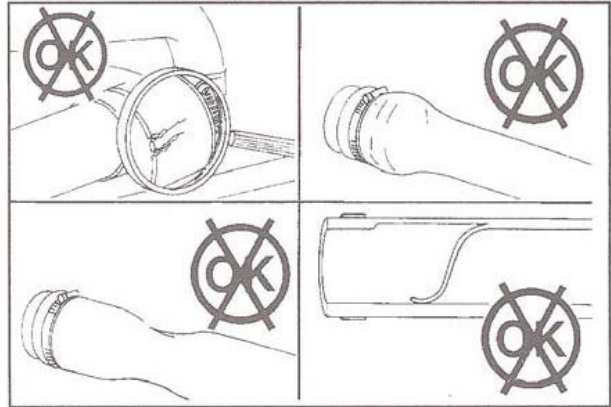

## Other Maintenance of the Engine

**Warning:** To prevent injury, do not carry out maintenance with the engine running if the maintenance must be done in the case that the engine is running, please make sure the operation will be completed by at least two persons, and it will comply with the following provisions.



One person must always sit in the operator seat, ready to turn off the engine. All the personal must keep in touch at any time.

When the operation is close to the fan, the fan belt or other rotating parts, there is the risk of being entangled by the components, so please pay special attention.

Do not drop or insert the tools or other objects into the fan or fan belt, otherwise, the parts will be broken or fly out.



**Warning:** Too much noise of the machine will cause temporary or permanent hearing problems. When doing the engine maintenance and prolonged exposure to the noise, you should wear earmuffs or earplugs during the work.

- **Checking the tension of the fan belt**

Check it for the first time after the first 50 working hours of the new machine, and after this, check it every 100 hours.

In order to ensure that proper work of the generator and service life of the belt, fan belt must be tensioned correctly.

For the proper belt tension, when you impose the weight of 6kg perpendicular to the belt between the fan belt and A/C compressor belt, the belt will have about 10mm subsidence.

If the belt was found broken, replace it.

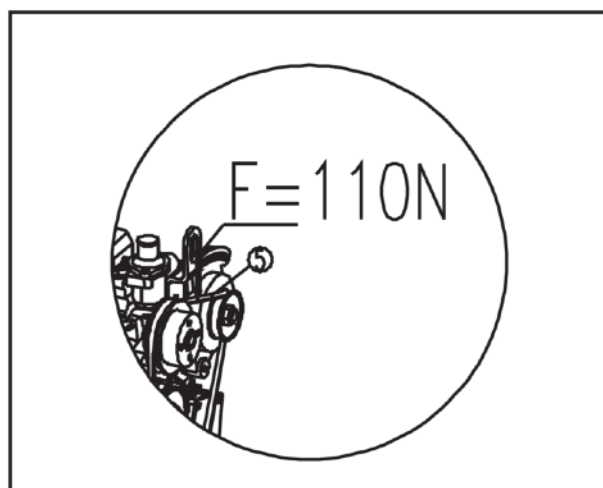

- **As to other engine components maintenance cycle and specific methods, please refer to "Diesel Operation Manual" attached to the machine.**

# Hydraulic System

## Maintenance instructions

Hydraulic Tank Capacity .....	264 liters
Oil level inspection .....	every 10 hours
Oil filter replacement .....	every 500 hours
Hydraulic oil change .....	every 1000-1500 hours
Checking the system pressure .....	every 500 hours



**Warning:** if the hydraulic oil or grease injects into the skin, it will cause serious injury and damage. Please prevent your hands and body close to the hydraulic oil leak area. You can check for leaks with cardboard or paper. If the hydraulic oil accidentally injects into your skin, please immediately go to the hospital for treatment.



**Warning:** to avoid burns, you can only do the related maintenance after the hydraulic oil has been cooled or when the oil is cold before the daily work. When removing the fuel filler flange cover, in order to prevent the oil spray, you need to turn the cover slowly to release the pressure inside.

## 1. Checking the oil level in the hydraulic tank

Check the oil level in the hydraulic tank every 10 hours. Figure 1

- 1) Stop the machine on the flat ground.
- 2) Start the machine to make each cylinder in the reciprocating motion.
- 3) Retract the stick cylinder and extend the bucket cylinder to make the bucket fall on the ground with the blade on the ground, and then turn off, as shown in the picture 1.
- 4) Observe the hydraulic oil level through the oil gauge on the hydraulic oil tank.

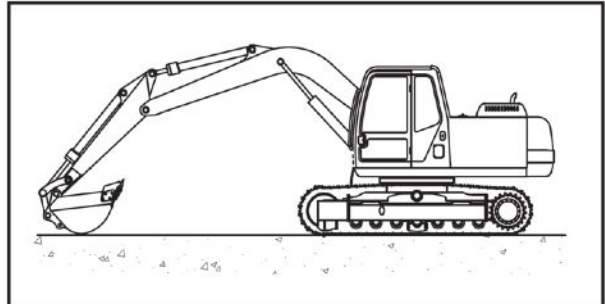
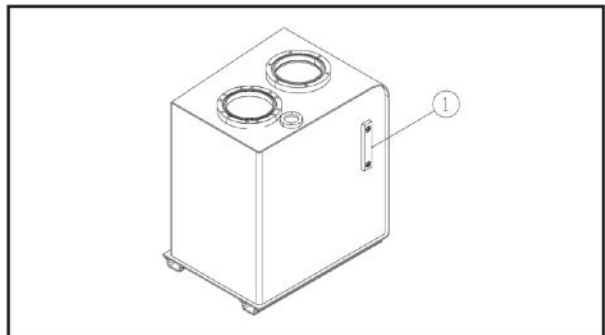

Figure 2



The level of the hydraulic oil can be observed through the oil gauge (shown in the picture 2 ①) It is required that the hydraulic oil level should be clearly seen within the range of the oil gauge, You cannot add too much oil that the oil level cannot be seen through the oil gauge, which will cause damage to the hydraulic oil lines or the oil spray. If the oil is too full, you have to stop the engine and discharge the excess oil through the oil drain plug port after the oil has cooled. If the hydraulic oil lever is low displayed in the oil gauge, or it cannot be seen, you should promptly refuel through the oil filler at the top of the hydraulic tank to raise the oil level.

**Note:** The hydraulic oil level will change with the rising of the oil temperature in the work. Before the operation, the oil level is in the middle of the oil gauge, while the oil level will be close to the top of the oil gauge due to the rising temperature in the proper operation.



## 2. Removing the water and dirt in the hydraulic tank

Remove the water and dirt in the hydraulic tank every 250 hours

- 1) After the oil temperature has dropped during the shutdown of the machine or before the daily work starting, expel the air in the oil tank.
- 2) Slowly release the oil drain valve at the bottom of the tank or the drain plug (as shown).
- 3) Discharge the water or dirt, until the clean and transparent hydraulic oil flows out. Re-close the drain valve or tighten the plug.
- 4) If the oil in the tank is insufficient, it should be added.

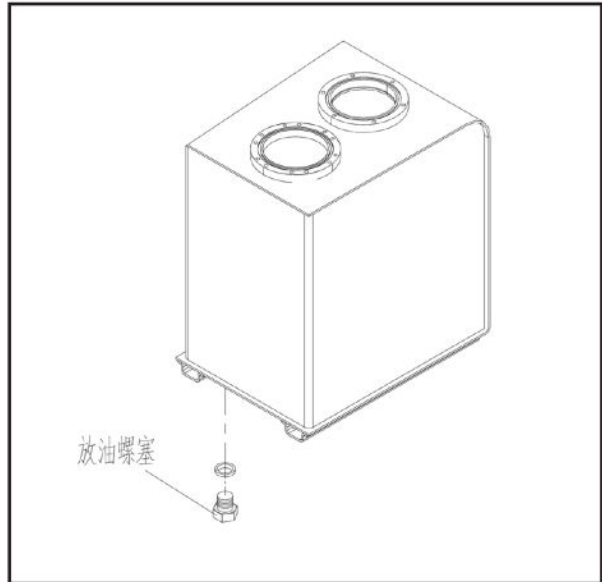

## 3. Replacing hydraulic oil and cleaning the oil filter

Replace hydraulic oil according to Table 5-30.



- Warning:**
- 1) To avoid burns, the oil can only be excluded after the hydraulic oil has cooled or before the starting of the daily work.
  - 2) When removing the fuel filter flange cover, in order to prevent oil spray, you should rotate the cover slowly to release the pressure inside.
  - 3) When changing the oil, be careful not to let the water oil, dirt, sand, etc. into the tank.

### Oil change procedures:

- 1) Stop the excavator on the flat ground.
- 2) Slowly release the air filter on the filler flange assembly of the upper part of the fuel tank, to lower the pressure of the air stored in the fuel tank.
- 3) Pump the hydraulic oil out with the pump, and put it into an empty oil drum.
- 4) Loosen the oil drain valve at the bottom of the tank or the drain plug, completely draining the remaining oil.
- 5) Remove the suction filter.
- 6) Clean inside the tank thoroughly.
- 7) Clean re-install the drain plug.
- 8) Clean the suction filter.
- 9) Add the required hydraulic oil (see the "Oil Selection Table"), making the oil level to the middle place of the oil gauge.
- 10) Install the suction filter and cover the air filter.

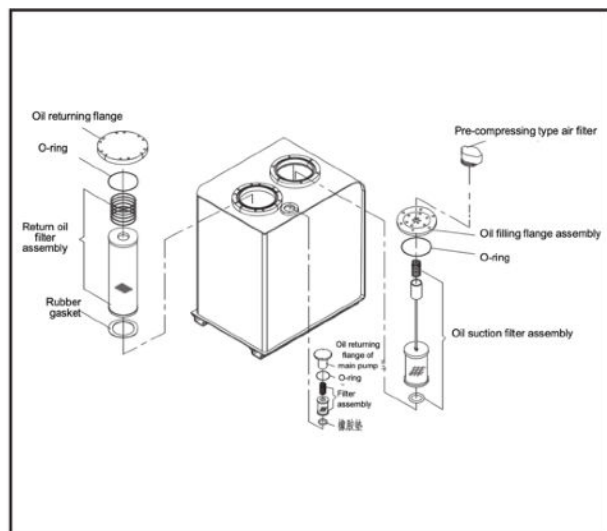



#### **4. Discharging the air in the hydraulic system**

##### **A. Discharging the air in the pump**

- 1) Release the air exhaust plug installed at the drain vent, and check if the oil flow out, completing the exhaust.
- 2) Tighten the bolt after the exhaust completion.

**Note: If run the pump when it is not full of oil, the pump will become abnormally hot, leading to the premature failure of it.**

##### **B. Discharging the air between the hydraulic pump and the tank**

- 1) Start the engine and keep it running at low or middle speed.
- 2) Operate the working device slowly to discharge the air.

**Note: If you keep the engine running rapidly before exhausting the air between the pump and tank, the pump will also have an abnormally high temperature, thereby damaging the pump.**

##### **C. Discharging the air in the cylinder**

- 1) When the engine is running at low speed, extend and retract the cylinder to the position about 100mm from the end of its trip four or five times.( remember not to the end of its trip)
- 2) Then, operate the cylinder to the end of its trip three or four times.
- 3) At last, operate the cylinder to the end of its trip four or five times, completing the air discharge,

**Note: If you let the engine running at high speed or operate it to the end of its trip the time the motor is just started, the air in the cylinder will cause damage to the piston seal, thereby damaging the cylinder.**

##### **D. Discharging the air in the rotating motor (when the oil in the rotating motor has been discharged)**

**Note: During the discharge, the machine cannot be rotated in any case.**

- 1) Idle the engine and release the exhaust plug, to check if the oil flows out from the exhaust plug.
- 2) If there is no oil flowing out, open the exhaust plug, then inject the hydraulic fluid into the motor housing.
- 3) After completing the exhaust, tighten the exhaust plug.
- 4) Finally, run the engine at low idle and slowly rotate the upper body of the machine to left and to right, twice respectively, to make the exhaust complete and full.

**Note: If the air within the motor is not discharged, the bearings of the rotating motor may be damaged.**

**E. Discharging the air within the walking motor (when the oil in the walking motor has been discharged)**

- 1) Idle the engine and release the exhaust plug. If there is oil flowing out, tighten the bolt.
- 2) Idle the engine, turn the working device 90° to make it located on one side of the track (as shown in the right picture).
- 3) Jacking the machine with the working device to make the track of one side slightly off the ground, and then run the track without load for 2 minutes. Repeat such operation to both the tracks and rotate the tracks forward and backward equally.

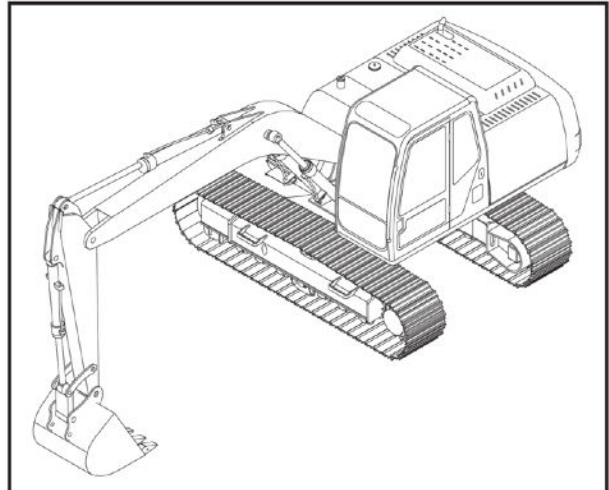

**F. Discharging the air within the accessories**

If you have installed the accessories on the machine, idle the engine, and operate the accessory pedal several times (about 10 times) until the air is discharged from the accessory pipelines.

**Note:**

1. **If the manufacturer provides the specific exhaust means, you should discharge the air in accordance with its provisions.**
2. **After completing the exhaust operation, turn off the engine. Before the operation, Please wait at least five minutes to clear the bubbles in the hydraulic oil tank.**
3. **There should be no leakage during the inspection. Wipe the oil spills.**
4. **After completing the exhaust operation, check the oil level. If the oil level is low, you should make fuel supplement.**

## 5. Replacing the filter element

Replace it for the first time after the first 250 hours of the new machine, and after this, replace it every 500 hours. The return oil filter is in the hydraulic tank, therefore,

- 1) Unscrew the lid at the top of the tank.
- 2) Remove the spring, the bypass valve and return oil filter from the tank.
- 3) Assemble the new filter element, clean and reassemble the spring and pass-by valve.
- 4) Install the fuel tank cap.

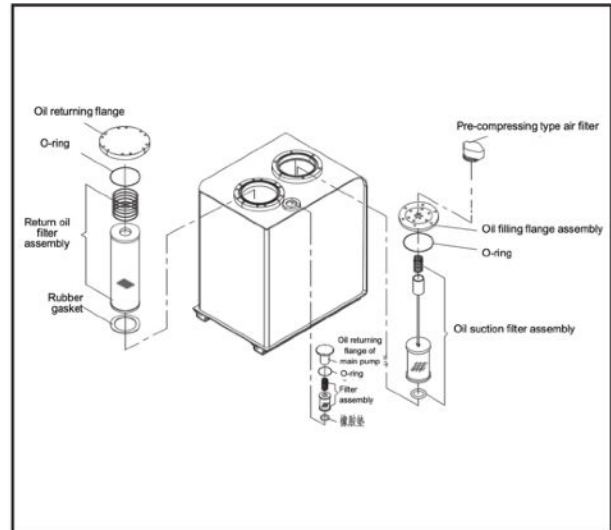

## 5. Assemble the new return oil filter element of the main pump

After the new machine has worked for 250 hours, do the first replacement. Afterwards replace the part every 500 hours. The return oil filter is inside the hydraulic oil tank, therefore:

- 1) Disassemble the oil returning flange of the main pump
- 2) Remove spring and return oil filter from inside of the oil tank.
- 3) Assemble the new filter element, wash and assemble the spring.
- 4) Assemble the oil returning flange of the main pump.

## 6. Replacing the filter element of the pilot oil circuit

Replace it for the first time after the first 250 working hours of the new machine, and after this, replace it every 500 hours.

**Note: Before the demolition of the filter element, you must exhaust the air pressure within the hydraulic tank.**

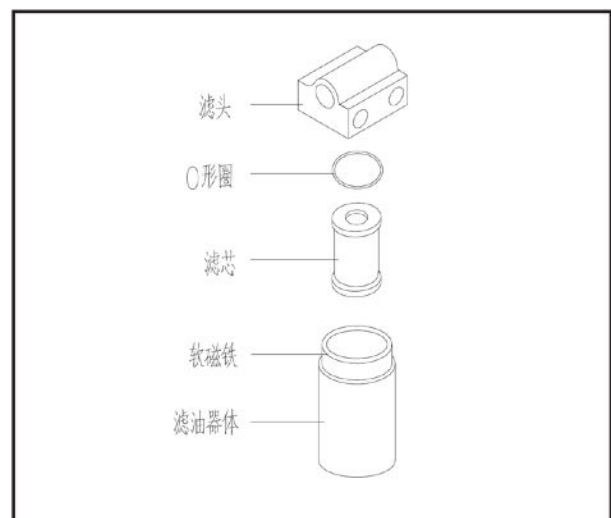



- 1) Unscrew the oil filter housing.
- 2) Remove the filter element.
- 3) Install the new O-ring in the groove of the filter head.
- 4) Before the installation of the new filter element, coat the filter seal surface with a layer of hydraulic oil, and then put the filter element into the filter head.
- 5) Clean the filter shell and the soft magnets, not allowing the dirt, dust or water enter the oil filter housing.
- 6) Tighten the filter housing and the filter head with the torque of 25-35Nm.
- 7) After connecting the pipelines, start the engine slowly. Keep it running continually for three to five minutes to discharge the air in the system.
- 8) After stopping the machine on the flat ground, check the oil level, and if necessary, you need to add the fuel. Please pay attention to that the oil level cannot exceed the required maximum oil level limits.

■ **The replacement cycle of the hydraulic oil and filter element when the accessories are being used (such as hammer)**

Use of hammer increases the pollution of the hydraulic system and accelerates the corrosion. Compared with the digging device, the replacement cycle of the hydraulic oil and filter element also should be shortened correspondingly, to avoid the damage to the hydraulic pumps and other hydraulic components. Recommended replacement cycles are shown in the following form: (unit: hour)

Hydraulic hammer operating rate	Hydraulic oil replacement cycle	Filter element replacement cycle
50%	500	500
100%	250	250

**Note: The system pressure should be adjusted appropriately according to the requirements of the hydraulic hammer when you are using a hydraulic hammer.**

## Battery



**Warning:** 1) Battery contains sulfuric acid liquid with a strong corrosive, so please keep it away from children, and the user should wear protective glasses and rubber gloves. Once the eyes, skin and clothing are splashed with sulfuric acid, wash with plenty of water promptly, and if serious, go to hospital for treatment.

2) Battery in charging will produce hydrogen and oxygen, so once it meets the open air or the exhaust port blocking, it will cause explosion. Therefore, the battery should stay away from the open fire and short circuit.

3) The battery, whose case is molded with polypropylene, is flammable, and should stay away from the open fire.

### 1. Battery storage

- 1) This series products are the lead-acid batteries of charge with liquid and should be stored at 5-25°C, dry, clean and ventilated environment, and should be free from the direct sunlight, at least two meters away from the heat source. Too high temperature will cause a great impact to the battery performance.
- 2) Batteries should not be put upside down or lying down, and can not be subject to any mechanical shock or suppression.
- 3) The storage period of the products of this series is six months, during which, the battery can be used without additional charge. The battery that has been stored for more than six months, can be used after the additional charge.

### 2. Battery charging

In the later of the charging, batteries will produce hydrogen and oxygen due to the electrolysis of water, resulting in water losses. The higher the charging voltage is, the more water is lost. This series of battery need not to be added water in the course of charging, so constant voltages charging method is highly recommended, and please avoid the constant current charging method as possible as you can.

#### 2.1 Battery additional charging

2.1.1) Constant current charging method

Charge the battery with the one-tenth current of the 20 hour battery capacity for 2-4 hours.

2.1.2) constant voltage charging method

Charge the battery with the constant voltage of 16V for 16 hours. (Maximum current does not exceed 25A).

#### 2.2 Battery normal charging

2.2.1) Continually charge the battery with the one-twentieths current of the 20 hour battery capacity for 1-3 hours until the battery voltage reaches 14.4V.

2.2.2) Charge the battery with the constant voltage of 16V for 24 hours. (Maximum current does not exceed 25A).



1) Batteries in charging will produce gas, so you should check regularly if the vent on the battery is locked to prevent the explosion.

2) When charging the battery, you should have the battery positive cathode connected to the charger positive cathode and the battery negative cathode connected to the charger negative cathode, and the reverse charge is strictly prohibited.

3) In the process of charging, if the battery electrolyte temperature exceeds 45 °C, reduce the charging voltage or charging current as appropriate, to prevent electrolyte splash due to the overheating.

### 3. Battery Installation

- 1) Before the installation of the battery, please pay attention to the safety standards on the battery label to prevent the unnecessary accidents.
- 2) Coat the side column of the battery with a small amount of Vaseline before the installation to prevent corrosion. Wiring should be solid and reliable. Side column percussion is strictly prohibited to prevent the acid infiltration due to the loose column.



- 3) Before installing the machine, you should first connect the battery positive cathode with the engine positive cathode, and then connect the battery negative cathode with the engine negative cathode.
- 4) Make the battery flat on the battery rack with the method of upper fixing or lower fixing, to prevent the battery from being damaged due to the looseness.

#### **4. Battery maintenance**

- 1) Battery cover is equipped with the indicator showing the state of charge. When the indicator shows green, the battery can be used normally; when the indicator shows black, the battery should be promptly charged; and when the indicator shows white, the battery should be replaced immediately.
- 2) Promptly charge the battery of power loss due to the various reasons in use to prevent battery performance decline caused by the sulfation.
- 3) Prevent over-charging the battery in use or in the process of charging. Avoid the premature failure caused by the water loss and grid growth.
- 4) For the battery in use, if it is not used for a long time (usually more than 15 days), you should remove it from the machine and store it in a ventilated and dry place. It should be charged additionally every 3-6 months (depending on whether the indicator is black).
- 5) As to the battery you have question with, please immediately contact the dealer to resolve.

## Reducer

### Maintenance instructions

Rotating reducer oil capacity .....	5 liters
Walking reducer lubricating oil capacity .....	5.4 liter
Checking the lubricating oil level and oiling .....	every 250 working hours
Replacing the lubricating oil .....	every 500 working hour
Checking the reducer bolt tightening torque .....	every 500 working hours

### 1. Checking the lubrication oil level of walking reducer and oiling



**Warning:** After a short time of machine walking, the oil in the reducer will be very hot. After turning off the engine, the walking reducer and the oil are still in the high temperature, which will cause serious burns. So before the operation, you must wait until the oil has cooled down. Loosen the exhaust plug two to three buttons to release the air pressure in the box, and then you can remove the plug. Rapid removal of plugs is dangerous.

Check it every 250 hours.

- 1) Prepare an Allen wrench.
- 2) Stop the excavator on the flat ground.
- 3) Turn the walking speed reducer, to let the 3 screws on its external end vertical to the ground, then stop the machine.
- 4) Open the screw ①, check lubrication oil level, which should be at the lower edge of the screw hole.
- 5) If necessary oil can be added (according to the following lubrication oil replacement steps)
- 6) Wash screw ① and reassemble it.

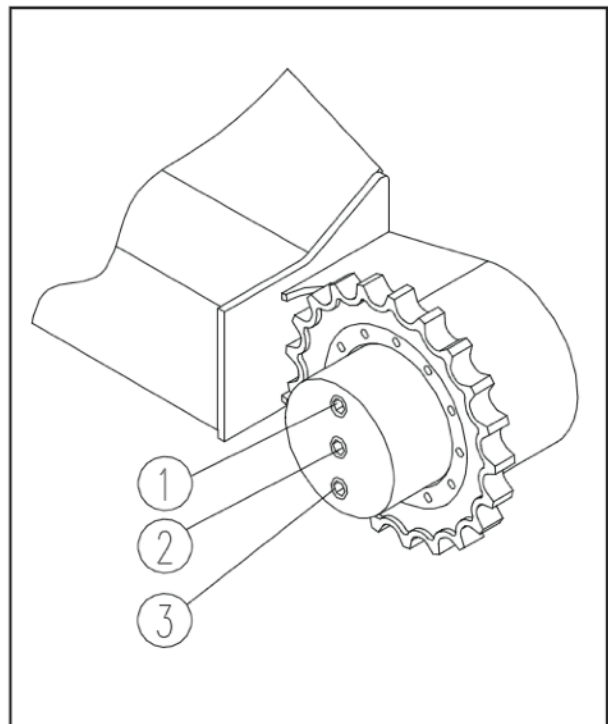

## 2. Replacing the lubricating oil( for each reducer box)

Replace it for the first time after the first 50 working hours of the new machine, and after this, replace it every 250 hours.

- 1) Prepare an inner hexagon wrench.
- 2) Stop the excavator on the flat ground.
- 3) Turn the walking speed reducer, to let the 3 screws on its external end vertical to the ground, then stop the machine.

**Note: Do not be burned by the hot oil.**

- 4) Open screw? When the reducer's oil is still hot to start draining oil. The oil should be completely drained.
- 5) Wash screw ② and reassemble it.
- 6) Add the required lubrication oil from hole ① till its level arrives the lower edge of the screw hole.
- 7) Wash screw ① and reassemble it.

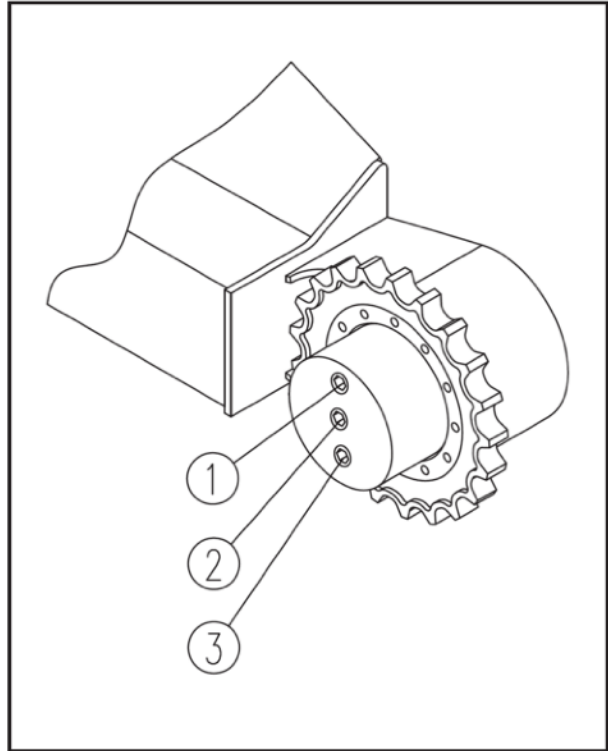

### 3. Checking the walking reducer and rotating reducer bolt tightening torque

#### A. Checking the fastening of the walking reducer connecting bolts

Check it for the first time after the first 50 hours of the new machine, and after this, check it every 500 hours.

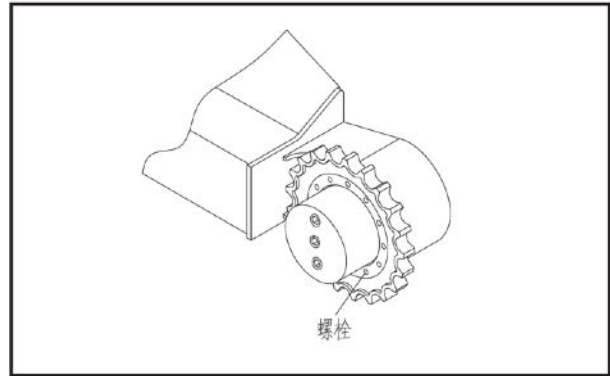

#### B. Checking the fastening of the rotating reducer connecting bolts

Check it for the first time after the first 50 hours of the new machine, and after this, check it every 500 hours.

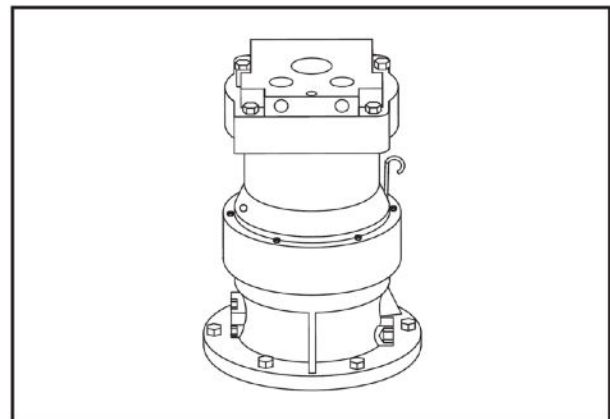

## Track

### Checking and adjusting the tension state of the track

Check it every 10 hours.

- 1) Stop the excavator on the flat and solid ground.
- 2) Take off the cover of each track carrier (No. ① of Figure 2).
- 3) In order to tension the track, you need to connect the Grease Gun connector with the connector ②(Figure 2). Then refuel with the grease gun till the branch volume f of the track is controlled within 2-4cm of deflection (Figure 1).
- 4) In order to loosen the track, firstly release connector ② (Figure 2) to make the grease flow out, and ensure that the branch volume f of the track is controlled within 2-4cm of deflection (Figure 1), and then re-tighten it.

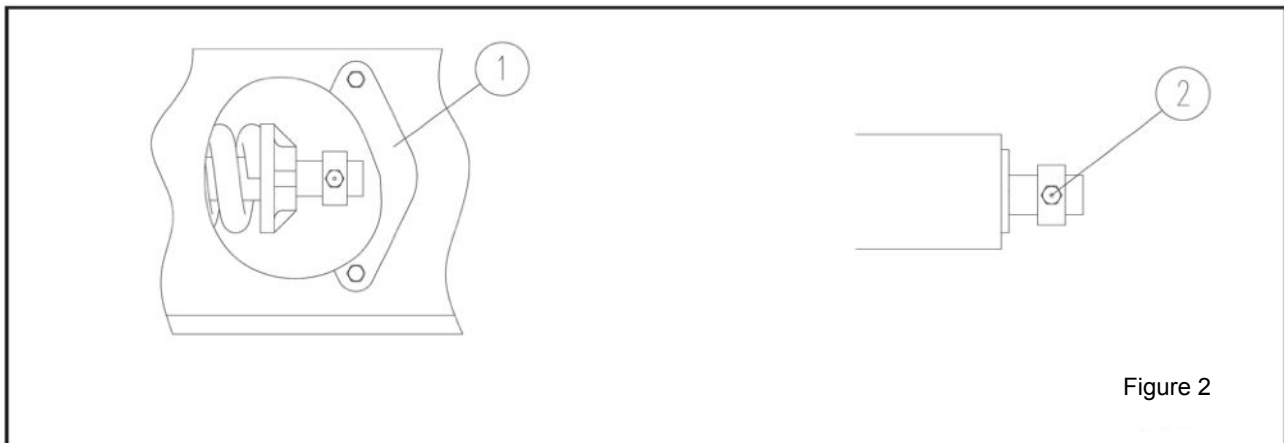
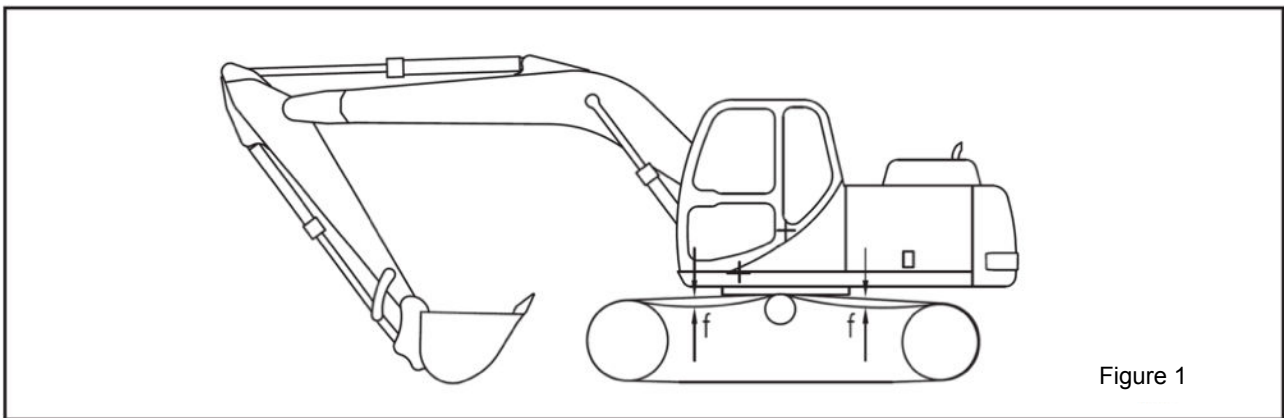



**Warning: Do not beat track tension springs, which will explosively fracture due to the enormous pressure, resulting in personal injury. Do not remove the spring under the tension state.**

## Supporting wheel, under roller and idler

### 1. Checking the tightening torque of supporting the wheel

Check it for the first time after the 50 working hours of the new machine, and after this, it should be checked every 500 hours.

If there is bolt looseness phenomenon, you need to unscrew the plug and clean the thread locking agent between the bolt and the thread, and coat the thread joints with the thread locking agent, and then tighten the bolt in accordance with the specified torque.

If the bolt must be replaced, the new bolt must be of the same size and the same strength grade.

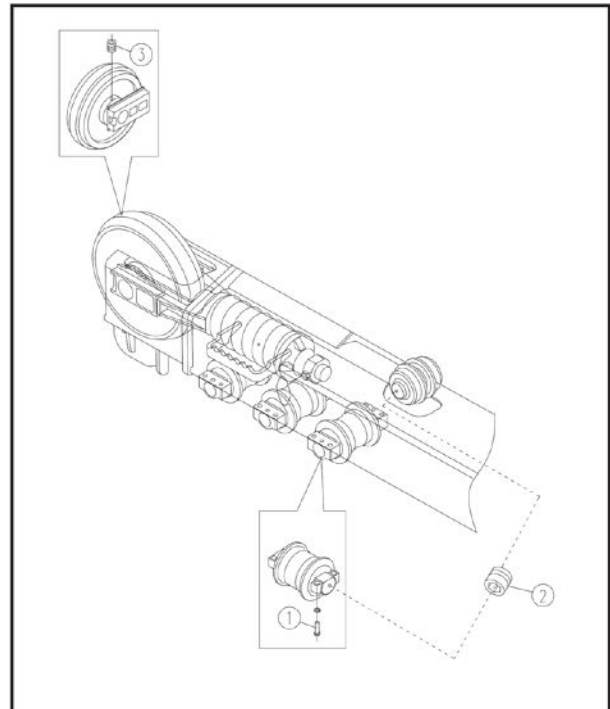

### 2. Checking the oil level of the under roller and the idler

Check it every 1000hours.

- 1) Remove the plug ② and plug ③ respectively from the under roller and the idler
- 2) Refuel with the oilier.
- 3) When there is oil flow out from the filling hole, re tighten the plug ② and plug ③.

1. Bolt of thrust wheel
2. Oil plug of support wheel
3. Guiding oil plug

## Lubricating

Lubricate each lubrication point of the machine every 50hours.

Lubrication steps:

- 1) Start the working device and put the bucket to the ground.
- 2) Put the blade to the ground.
- 3) Turn off the engine.
- 4) Clean the refueling nozzle of each oil cup.
- 5) Lubricate all the lubrication points and wipe the excess grease that is squeezed.

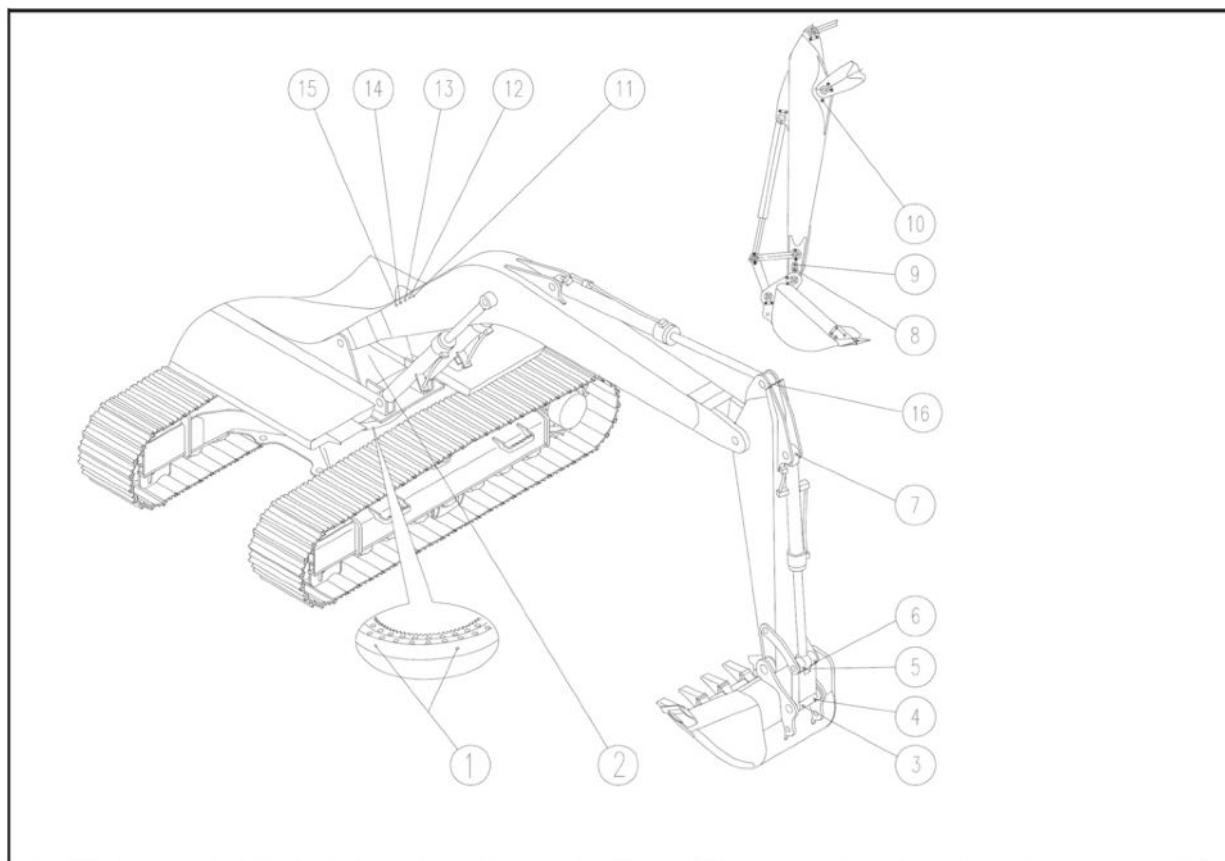

- |  |   |  |
|--|---|--|
| 1. Lubrication point of the rolling passage of slewing support | 8. Hinge connecting point of bucket and bucket rod      | 15. Lubrication point of boom pin shaft                    |
| 2. Lubrication point of slewing support's speed reducer        | 9. Hinge connecting point of rocking rod and bucket rod | 16. Lubrication point on the tail of the boom oil cylinder |
| 3. Hinge connecting point of bucket and connecting rod         | 10. Hinge connecting point of boom and bucket rod       |  |
| 4. Hinge connecting point of bucket and connecting rod         | 11. Lubricant point of the boom cylinder                |  |
| 5. Lubrication point of connecting rod and rocking rod         | 12. Lubricant point of the stick cylinder               |  |
| 6. Lubricant point of the head of stick cylinder               | 13. Lubricant point of the boom cylinder                |  |
| 7. Lubrication point on the tail of bucket rod's oil cylinder  | 14. Lubrication point of boom pin shaft                 |  |





## Air Conditioning

The machine is equipped with the air conditioning device in the cab, and its operation knob is on the left control box in the cab.

As to the specific operation and maintenance of the air conditioning system, you can not only refer to this operation manual, but also the Air conditioning operation manual attached to this machine.

### 1. Precautions for the air conditioning maintenance

- 1) If the graphics  flicks on the manipulation screen, then the cooling system pressure has failure. The compressor does not work and the system cannot cool down, when you should find a professional to repair.
- 2) Automatic shutdown after the starting (the manipulation screen goes off after going on) or the graphics  flicking (about 5 minutes) shows that non-normal power failure is occurring or non-normal power failure has occurred at the beginning of last starting (for example, turn off the power switch without turning off the air conditioning control power, insurance is burned in the process of the starting the air conditioning, power cable connection is poor, etc.). At this point, if the graphics  stop flicking 5 seconds after starting, then the air conditioning can be used continually; if you cannot boot or it automatically shut down after the boot, and then check whether the air conditioning power supply circuit is open, or the connection is bad.
- 3) To protect the compressor, the compressor start interval is set for 15 seconds in this machine, so if the time of choosing cooling from the last cooling choice time is less than 15seconds, it is normal that the compressor does not run. After the interval of 15 seconds, the air conditioning system will automatically accept your instructions of cooling.
- 4) Air conditioning air filter box assembly must be cleaned regularly once a month, otherwise dust and dirt can clog the network, and the indoor air cannot smoothly go through the heat exchanger, affecting the effectiveness of the air conditioning.
- 5) In special conditions (such as wet, the not very hot environment, the use of outside air circulation, low-speed blower running, dirty and clogging air filter, return air blockage, etc.), if you use the strong cooling for a long time, you will sometimes feel the wind is smaller and smaller, or even almost no wind, which is the performance of air conditioning evaporator frost. The frost on the evaporator blocks the air circulation flow channel, making the cooling effect if poor. However, this is not a fault. As long as you suspend the cooling, remove the dirty block and select the wind, then a few minutes later, choose the cooling, it can return to normal. After returning to the normal use, do not select wind, strong cooling, and outer loop at the same time, for example, you can select the weak cooling or the middle cooling.
- 6) When using the heating system in the winter, you should wait the engine water temperature has increased before use.
- 7) Heating core tank is connected with the engine water tank, so once the heating core leaks, the water tank will be lack of water, making the engine overheating. In the winter, to prevent the coolant from freezing is as important as to protect the water tank from cracking. To prevent the coolant freezing leading to the cracking of the heating core tank and the water tank, please use the specified coolant. Because in winter, the coolant may freeze easily, if necessary, if the standby time is long, please let the coolant out. Please note: heating core tank cracking in the winter is not within the scope of "three guarantees". In addition, the heating core tank corrosion and leakage, warm water valve damage due to the coolant that is not in accordance with the requirements of the manufacturer are also not within the scope of "three guarantees".
- 8) Refrigerant easily frostbites the skin, especially the eyes; in addition, it will emit toxic phosgene in case of meeting the open fire. Therefore, under any situations that the cooling system needs to be demolished, please recover the refrigerant before disassembling the cooling system. The whole process should be free from flame!
- 9) When the cooling system is not used for a long time, it should be run every half a month for 5-10 minutes each time.

## 2. Checking the amount of the refrigerant



Refrigerant easily frostbites the skin, especially the eyes; in addition, it will emit toxic phosgene in case of meeting the open fire. Therefore, under any situations that the cooling system needs to be demolished, please recover the refrigerant firstly in the case that the refrigerant will not spray to the skin and eyes, and then demolish the cooling system. Please make sure that there is no open flame during the whole process.

If the refrigerant is insufficient, the cooling performance will be very poor. Therefore, check the amount of the refrigerant every month or every 250 hours.

In the case of the engine idling at high speed, operate the air conditioning in the state of strong cooling, check and determine the amount of refrigerant according to the bubbles on the sight glass of the drying bottle.

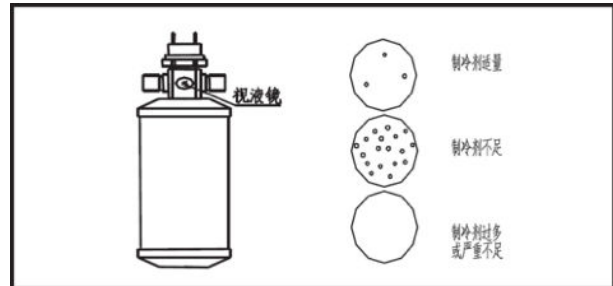

## 3. Checking, adjusting the tension of the air conditioning compressor belt

Check and adjust the tension of the air conditioning compressor belt every 250 hours.

### A. Checking

Press the belt in the middle between the driving wheel belt and the compressor belt with the finger force of 12N, and check if the deflection is about 5-7mm.

Check if the belt is damaged. If the belt has been stretched without the margins for adjustment or it has cuts or cracks on its surface, please replace with a new belt.

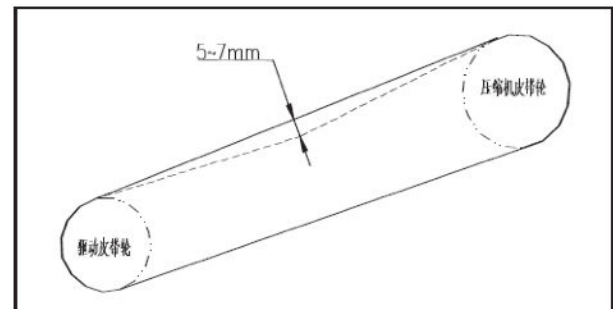

### B. Adjusting

Adjust the nut No. 2, the max. Deflection when a force of 6kg is applied to the max. Belt span should be 10mm, and then tighten the two No. 2 nuts.

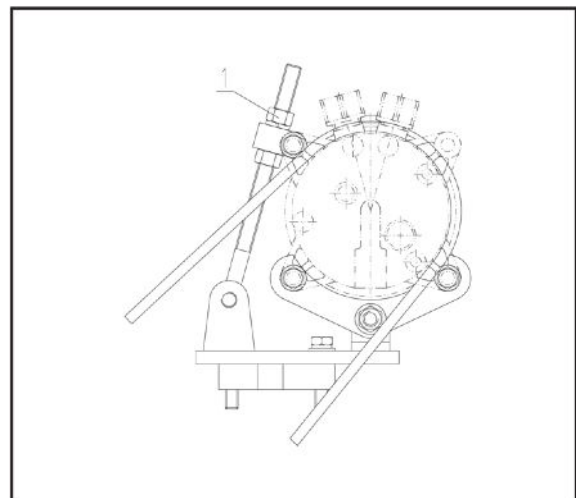

#### 4. Air conditioning regularly inspection contents

No.	Inspection items	Inspection contents	Inspection cycle	
			Per month	Per season
1	All fasteners	Looseness or drop	★	
2	Air conditioning belt	Tension and wear	★	
3	Pipelines	Wear or cracking	★	
4	Connector	Wear of leakage		★
5	Electric fan	If run properly	★	
6	Harness	Wear, tear and scorch	★	
7	Condenser	Dirt clogging on the surface		★
8	Electromagnetic (compressor)	Slipping	★	
9	Compressor	Any abnormal sound		★
10	Amount of coolant	If the sight glass has bubbles	★	
11	Dust filter	Any dirt clogging	★	

## Bucket Teeth Replacement

Replace the bucket teeth before the wear of the bucket seat.



**Warning:** when replacing the bucket teeth, the accidental movement due to the misuse of the working device is very dangerous. Therefore, before replacing the bucket teeth, you have to place the working device in the locked state, shut down the engine and have all the operating stick firmly locked. In the replacement, wear the necessary protective equipment to prevent items flying out of the lock pin.

### Replacing bucket teeth

- 1) Place the bottom of the bucket on the pad to remove the pin. Check if the working device is in the locked state, and place the bucket horizontally. Then lift the safety lock lever on the left control box, making the machine in the locked state, and turn off the engine.

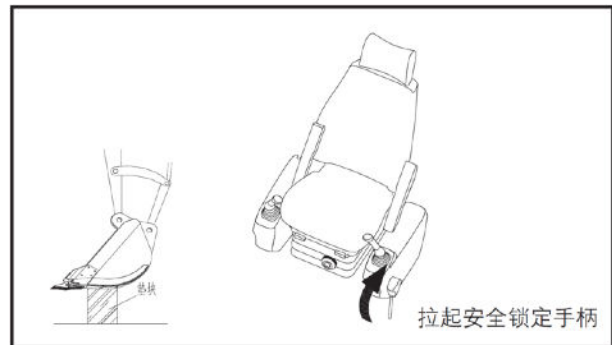

- 2) Put a metal rod whose diameter is slightly less than that of the pin on the pin head, knock it with a hammer, and remove the bucket teeth.
- 3) Clean the mounting surface. Put the new teeth into the teeth seat, push the pin partially into by hand, and then knock the pin into with a hammer to fit the bucket to the bucket seat.

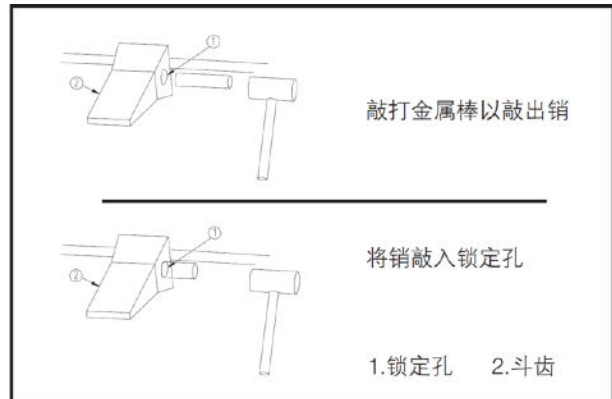

## Washing the Floor Pads

Clean the floor pads whenever it is dirty to prevent the accidents due to the slipping or falling.



**Warning:** if you hit the stick accidentally, the working device will move suddenly, causing a serious accident. Therefore, before removing the floor pad, you must stop the machine on the flat and solid ground. Before the operator stands up, he must lift the pilot safety handle and the control box above it, locking the pilot system.

### Floor pads washing steps:

- 1) Take the floor pad out of the cab.
- 2) Remove the dirt with s brush or wash the floor pad directly with water
- 3) Clean the floor of the cab with a dry mop. .
- 4) Put the floor pad back to the cab after it has been dried.

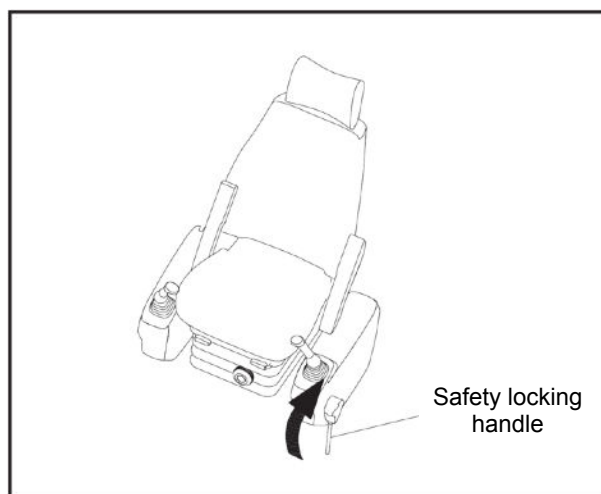

---

**Accessory Guide**

## Safety issues

If the accessories or options that have not been approved by Yuchai are installed, this will not only affect the service life of the machine, but also can cause some safety problems.

When installing the accessory that has not been approved by Yuchai, please contact Yuchai dealer firstly.

If you do not contact Yuchai, we will not assume any liability to the accident or damage.

### 1. Safe operation of accessories

- Accessories have a strong auxiliary function. To prevent serious injury or damage, you have to use the accessories properly.
- Before you have a full understanding of the contents of the operation manual, do not use the accessories. If the instruction manual is lost, ask the manufacturer or the company that sells the accessories for a new manual.
- According to the conditions of accessories, the necessary front guard should be installed on the machine.
- According to the case of accessories, vibration noise, my colleagues will make the conveyance of instructions between the colleges very difficult. So, before starting the operation, assign a command and determine the signal to be used.
- In the case of heave load on the accessory, do not do the rotating operation of turning to the side, especially on the slope. Such operation is very dangerous.
- Compared with the machine equipped with a bucket, the machine equipped with a breaking hammer has heavier load in the front and is unstable. To avoid the risk of tipping, do not carry out any operations during the accessory rotation to the side.
- After the machine has been equipped with accessories, you have to set out a cordon around the machine to prevent the personnel from entering. When someone is near the machine, do not operate the machine
- Before starting the operation, you should set up a cordon around the machine to prevent personnel. When someone is near the machine, do not operate the machine.
- To prevent serious accidents caused by misuse, do not put your feet on the pedal unless for the operation.
- When the machine is fitted with an accessory, if the accessory is recovered to the direction of the machine body, it will be interference with the body, so please operate the accessory carefully.

### 2. Removal or installation of accessories

When removing or installing the accessory, be sure to do according to the following steps go ensure the operation safety:

- Removal and installation should be carried out on the flat and solid ground.
- When the operation is done by two or more persons, you should determine the signals and comply with these signals in the operation.
- When upgrading or moving heavy objects (over 25 kg), be sure to use the crane.
- When removing the heavy components, you have to support them with a crane before removing. When using the crane, please pay particular attention to the position of the gravity center.
- When lifting the heavy loads with a crane and if it is dangerous, prepare a stand and ensure that its state is safe.
- When placing the removed accessory, make sure that it is stable and cannot overturn.
- Do not walk under the load lifted by the crane. You should stand at the place that even if the load falls down, it has no danger.



**Warning: The person who operates the crane must have the operation qualification. The people without qualifications are not allowed to operate the crane. For the details of the removal and installation, Please contact Yuchai dealer.**



## Accessories Installation and Removal Steps

### 1. Removal procedures

- 1) Place the accessory on the ground and turn off the engine
- 2) Turn the starter switch to "ON" position and push the left control box to the free position.
- 3) Do the full-stroke operation of forward, backward, left and right to all the work units stick and accessory control pedal to eliminate the internal pressure in the hydraulic circuit.
- 4) After the oil temperature is reduced, lock the switch valve connected to the stick side inlet and out let pipe.
- 5) Remove the side hose of the accessory and tighten then washer on the blocking plug to the two exports.
- 6) Remove the accessories by removing the pins (2) and then install the bucket.
- 7) Strap the two unconnected hose ends of the hydraulic hammer with a clean plastic bag, doing dust control measures. Store the accessory proper.

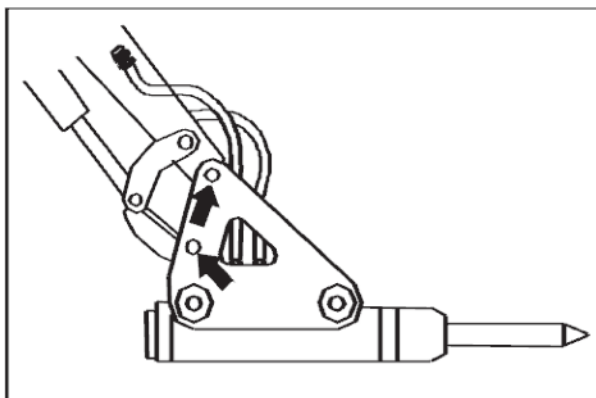

### 2. Installation Steps

- 1) Remove the bucket.
- 2) Place the accessory at a flat place, connect the stick and hydraulic hammer with pin A and connect the connecting rod and hydraulic hammer with pin B.
- 3) After the temperature is reduced, respectively remove the bolts from the export and import. Be careful not to allow dust, dirt, etc. Stuck to the hose interface parts. If the washer is damaged, replace it with a new one.
- 4) Connect the hose on the accessory side. When connecting, check the flow of the oil and do not connect it wrongly.
- 5) Release the switch valve lock connected to the stick side inlet and outlet pipes.
- 6) After the installation of accessories, make sure the oil level in hydraulic tank is in the right place.

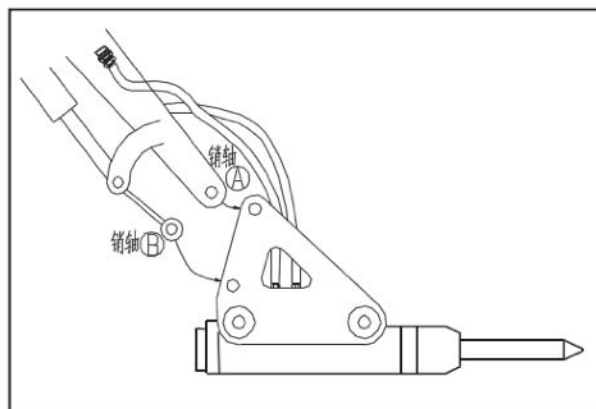

## Accessories Instruction Guide

This section describes when operating the hydraulic excavators with accessories, the precautions to be observed.

**Note: Choose the accessory most suitable to the host. The models of the accessory that can be installed are different. For accessories and machine model selection, please contact Yuchai Dealer.**

### Hydraulic Breaking hammers

#### 1. Hydraulic Breaking hammers operation Guide

Hydraulic Breaking hammer is the most common seen work accessory, which is widely used including demolition of buildings, breaking of roads, tunnel operation, breaking of steel slag, breaking of stone and the breaking operations in the quarry.

- 1) When doing the breaking operation, make sure Breaker Chisel point in the direction perpendicular to the surface of the object, and keep it as far as possible. If not, the drill may slide from the surface, which will cause damage to the drill and affect the piston.

In the breaking, please select the appropriate blow points, and make sure the drill rod is stable, and then begin blowing.

In operation, it is required to adjust the bucket cylinder to keep the drill rod penetrating direction and the body of breaking hammer in the same line.

- 2) When the shock is applied, press the drill rod down to the shock surface, with the chassis from the ground about 5cm. Do not let the machine off the ground too much.

- 3) When making continuous shock to the same shock surface, if the drill rod cannot penetrate or break the surface in 1minute, change the shock position and do the breaking near the edge of the surface

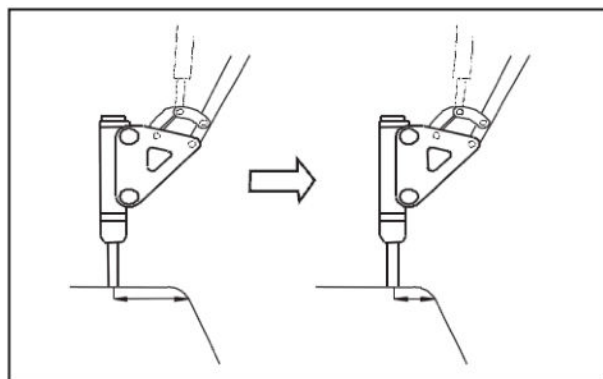
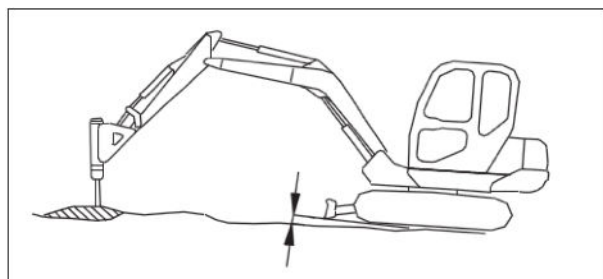
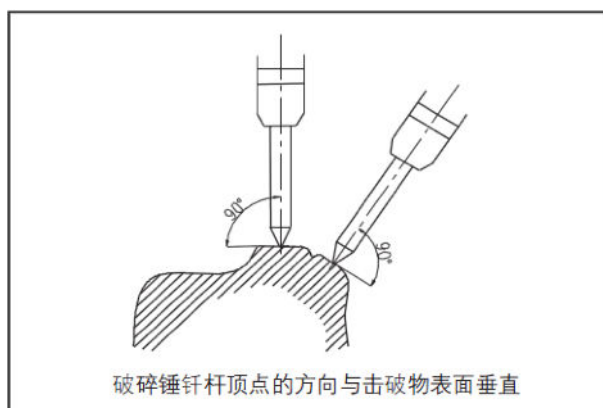

- 4) Maintain the drill rod blow the surface appropriately to prevent the use of the impact when there is no resistance.

When the target or rock has been crushed, please stop the blow action of the breaking hammer immediately. Blowing of continuous and aimlessness can only cause the precursor and the main bolt loose and damaged, or even cause damage to the excavator itself.

Aimless blowing is due to the properly inserting, as well as shaking the breaking hammer.

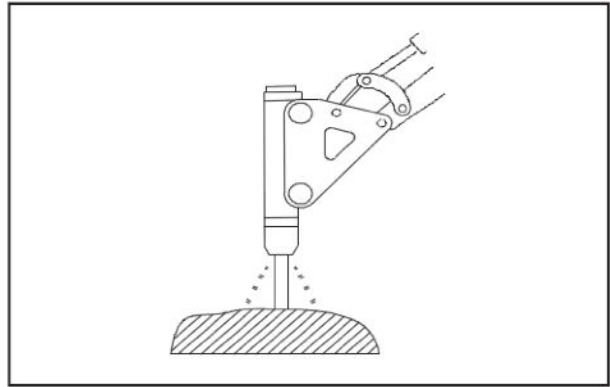

## 2. Hydraulic breaking hammers operation taboo

To ensure that the machine has a long life and ensure the safe operation, do not operate the machine in any of the following ways:

**Note: Do not operate all cylinders to the end of the cylinder stroke, and about 5 cm margin should always be kept.**

- 1) Push heavy objects or large stones with the breaking hammer.

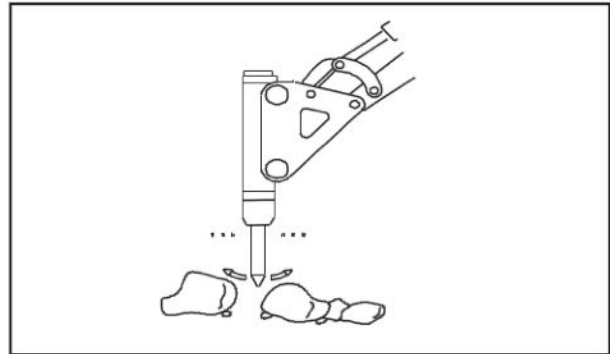

- 2) Operate with the rotation power

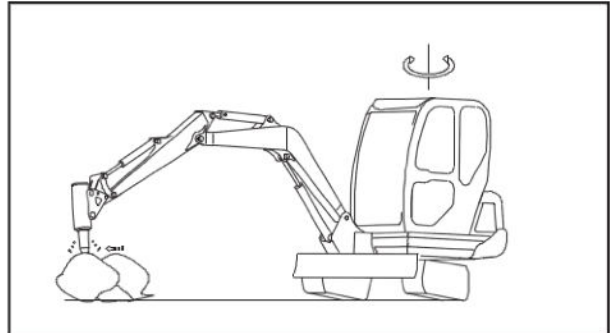

3) Move the drill pod in the impact operation.

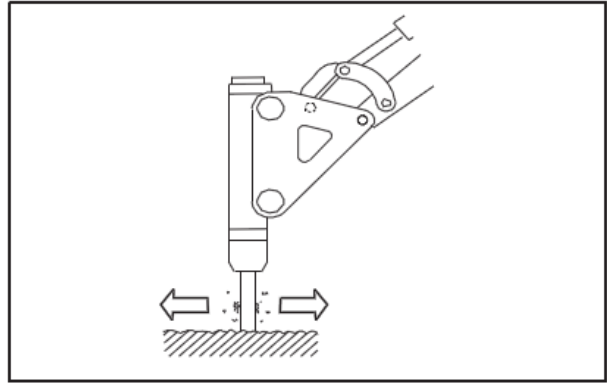

4) Apply impact force in the level or upward.

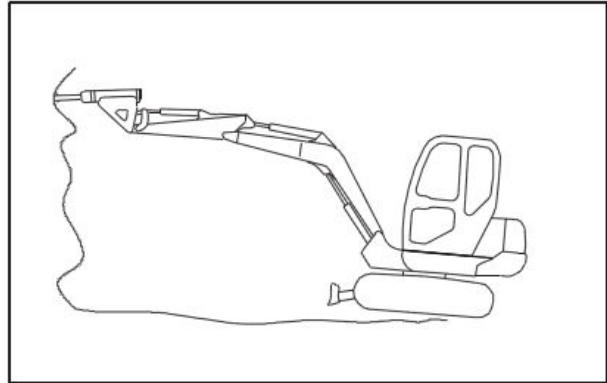

5) Swing the drill rod when it has been penetrated into the rock.

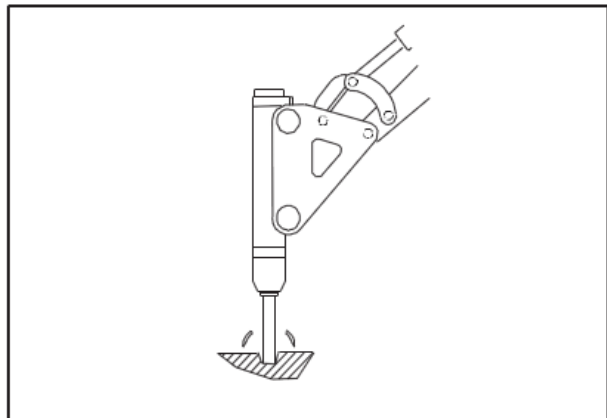

6) Pecking operation.

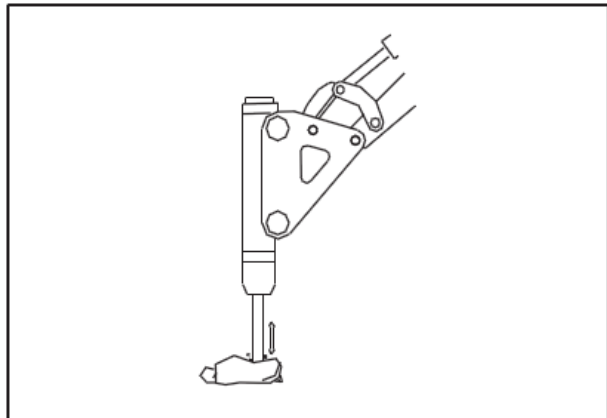

- 7) Operation in the water or in the muddy ground.

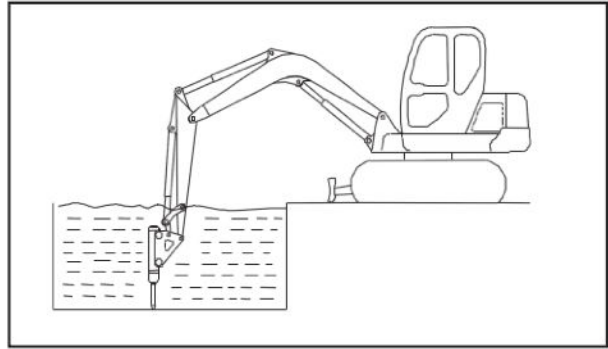

- 8) Use the breaking hammer as a tool for lifting heavy objects.

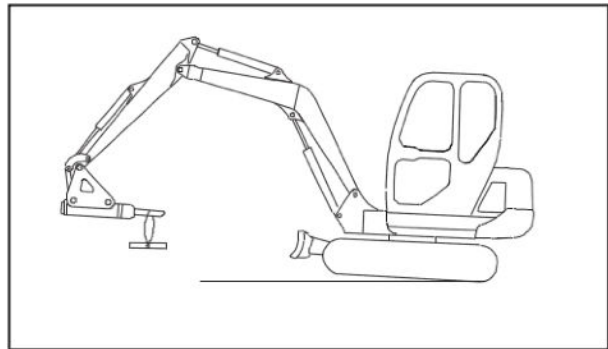

- 9) Make the bucket cylinder fully extended and the machine off the ground.

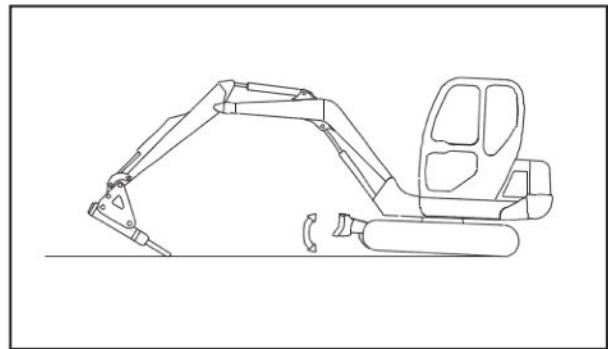

## Quick-acting Couplings

### 1. Bucket Installation

- 1) Pry ① with a crowbar.

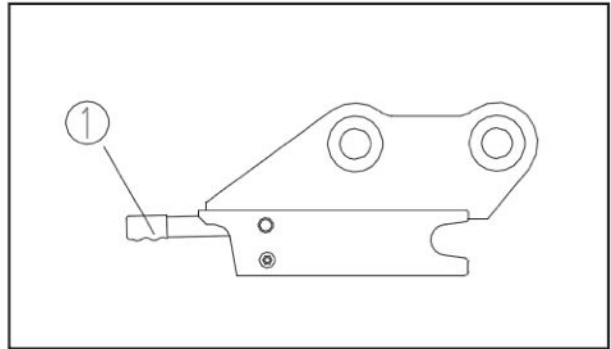

- 2) Place the bucket pin into the position of ②③, put down the crowbar, and the bucket is installed

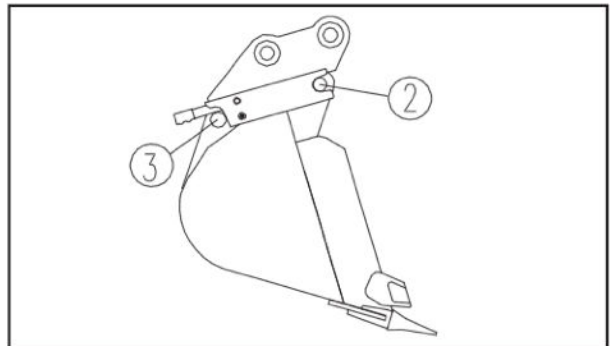

### 2. Bucket Removal

- 1) Pry ① with a crowbar.
- 2) Remove the bucket.

## Daily Inspection of Hydraulic Breaking Hammer

Do the daily inspection and maintenance for hydraulic breaking hammer according to the following table:

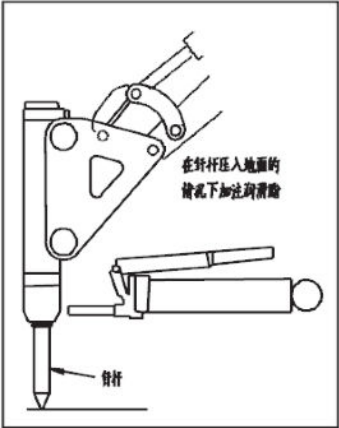
Number	Inspection or maintenance items	Inspection points	Maintenance way
1	If bolts and nuts are loose or lost	Main bolts and side bolts	Tighten the bolts or re-install a new bolt
2	Check hoses parts for looseness, damage or leakage	Hydraulic breaking hammer piping High-pressure pipeline	Re-tighten the loose parts; Replace the seriously damaged parts.
3	Lubricating 	Before the operation or the in the continuous operation of 2-3 hours, the lubricating oil should be used. Inject lubrication oil 5-10 times for each lubricating.	Inject lubricating oil from the oil hole of on the precursors of the breaking hammer.
4	Check the hydraulic oil capacity and pollution	The status of hydraulic oil	Hydraulic oil mass ratio change is different due to the different working environment. A simple way to judge the change of the oil mass if to observe the oil coloure. If the oil turn bad seriously, please immediately discharge the hydraulic oil in the hydraulic tank and after cleaning the tank, inject the new hydraulic oil.



**Yuchai Machinery**

**Guangxi Yuchai Heavy Industry Co., Ltd.**

Address: No. 168 Bridge Road, Yulin City, Guangxi Province, China (537005)

Telephone: (0775) 3289567 3287255

Fax: (0755) 3813592